

(R-82-853)

RESOLUTION NUMBER R- 255456

Adopted on DEC 7 1981

BE IT RESOLVED, by the Council of The City of San Diego, as follows:

That a portion of Lot "A" of Penasquitos Park View Estates Unit No. 3, Map No. 10043, as more particularly shown on Drawing No. 19954-D marked "Exhibit A" which is attached hereto and made a part hereof, be, and the same is hereby set aside for drainage purposes.

That the City Clerk shall cause a certified copy of this resolution, attested by him under seal, to be recorded in the office of the County Recorder.

APPROVED: John W. Witt, City Attorney

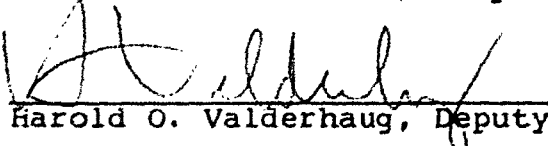
By 
Harold O. Valderhaug, Deputy

HOV:ps:710.5
11/16/81
Or.Dept: E&D
T.M. 79-149
W.O. 71259
19954-D

01028-00001

1991 NOV 20 PM 4:22

SAND EGG SHELL

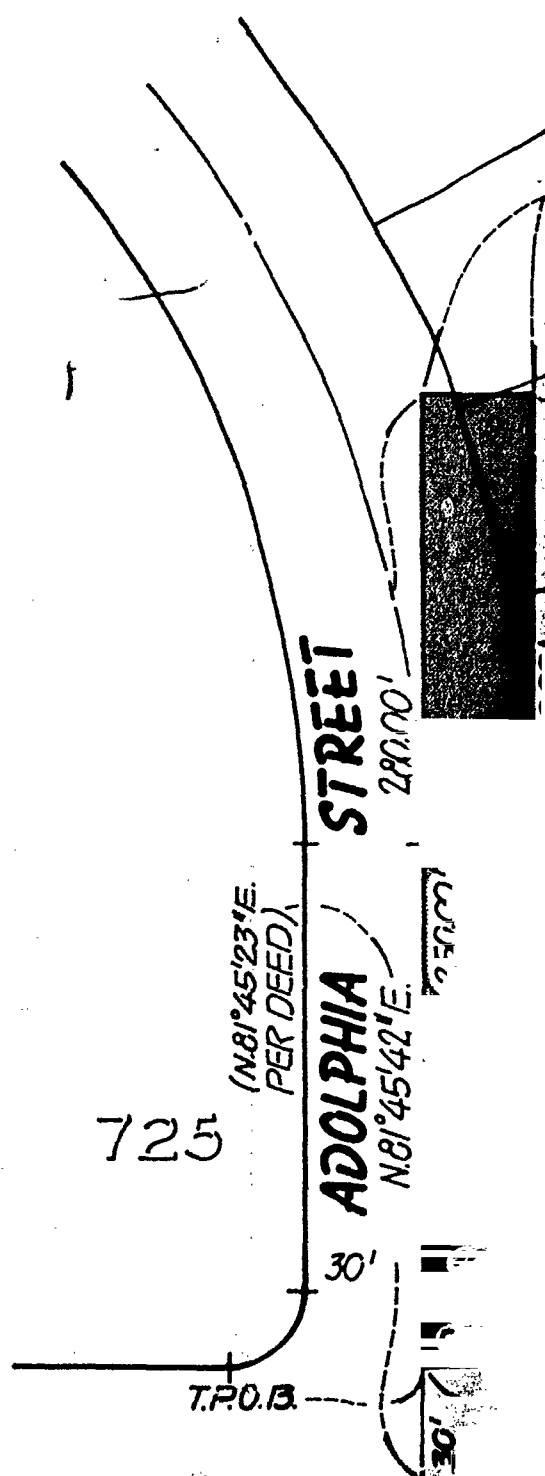

C1028-00002

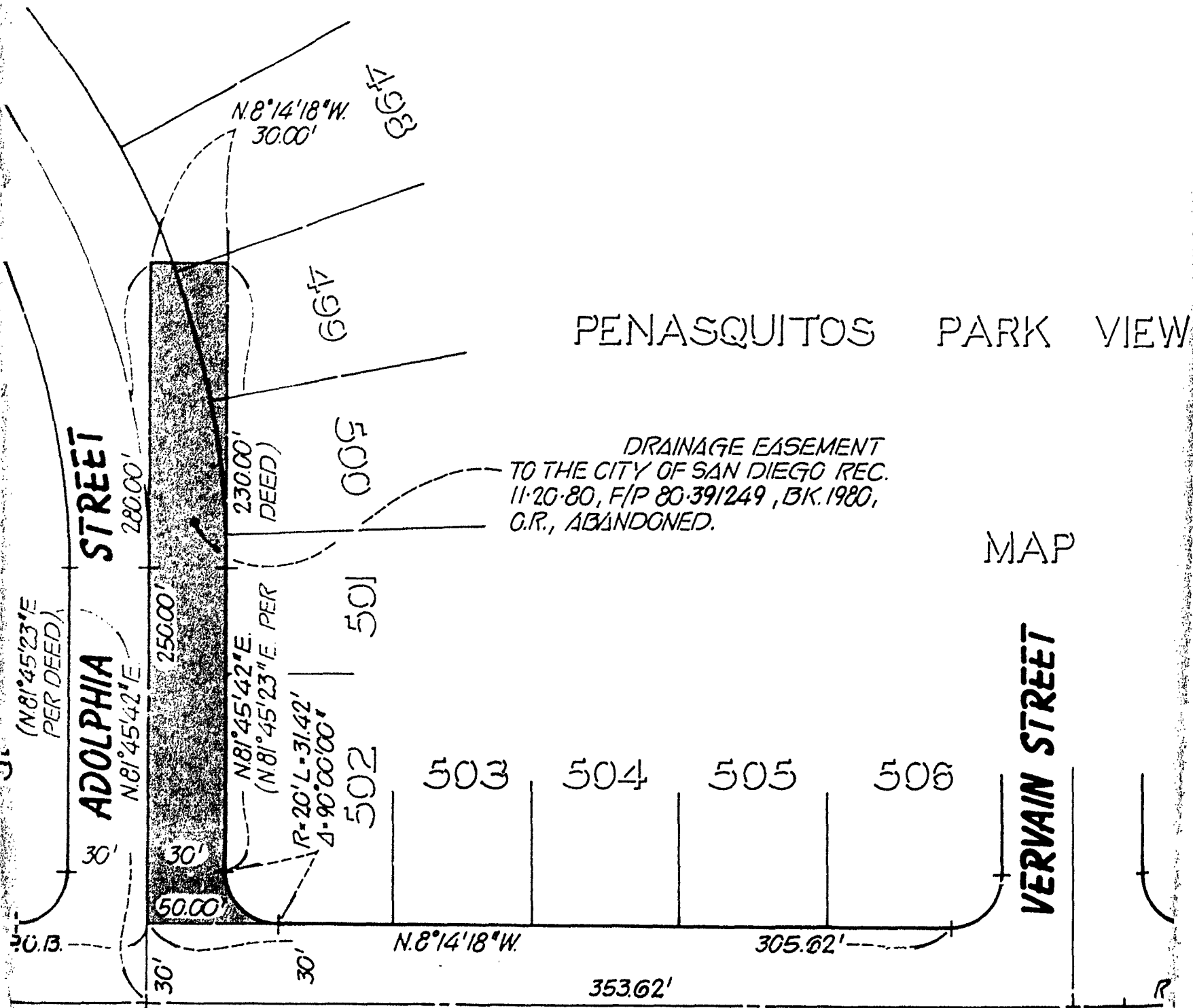

01028-00003

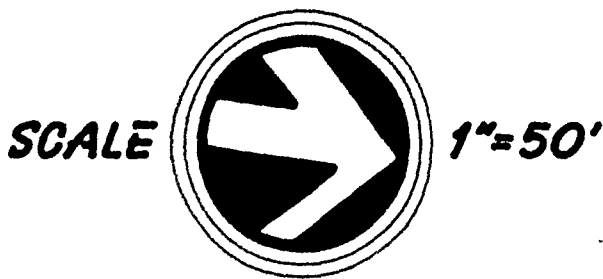

ARK VIEW ESTATES

DRAINAGE
TO THE CITY OF S
11-20-80, F/P 80-
O.R., ABANDONED.

UNIT NO. 3

MAP NO. 10043

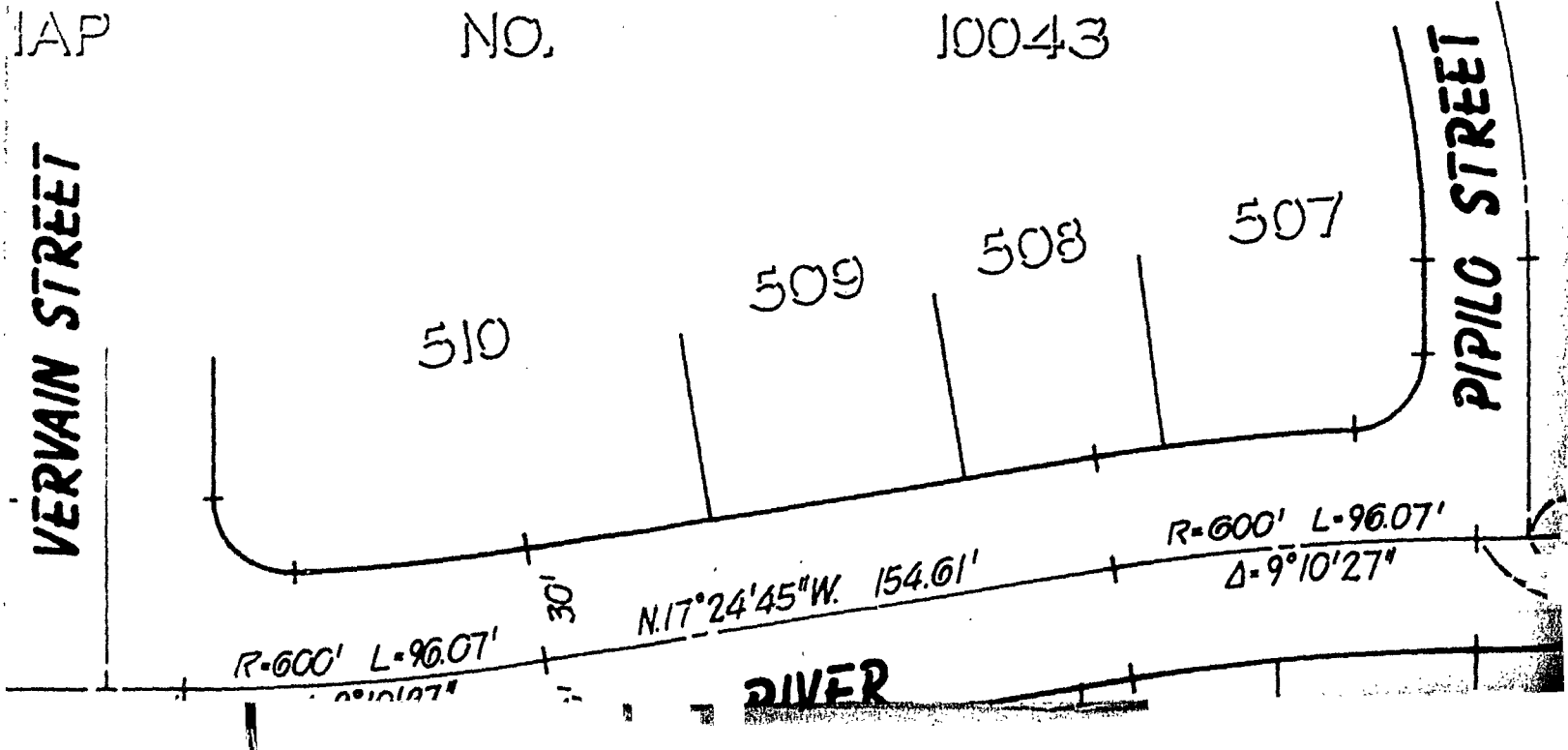

01028-00001

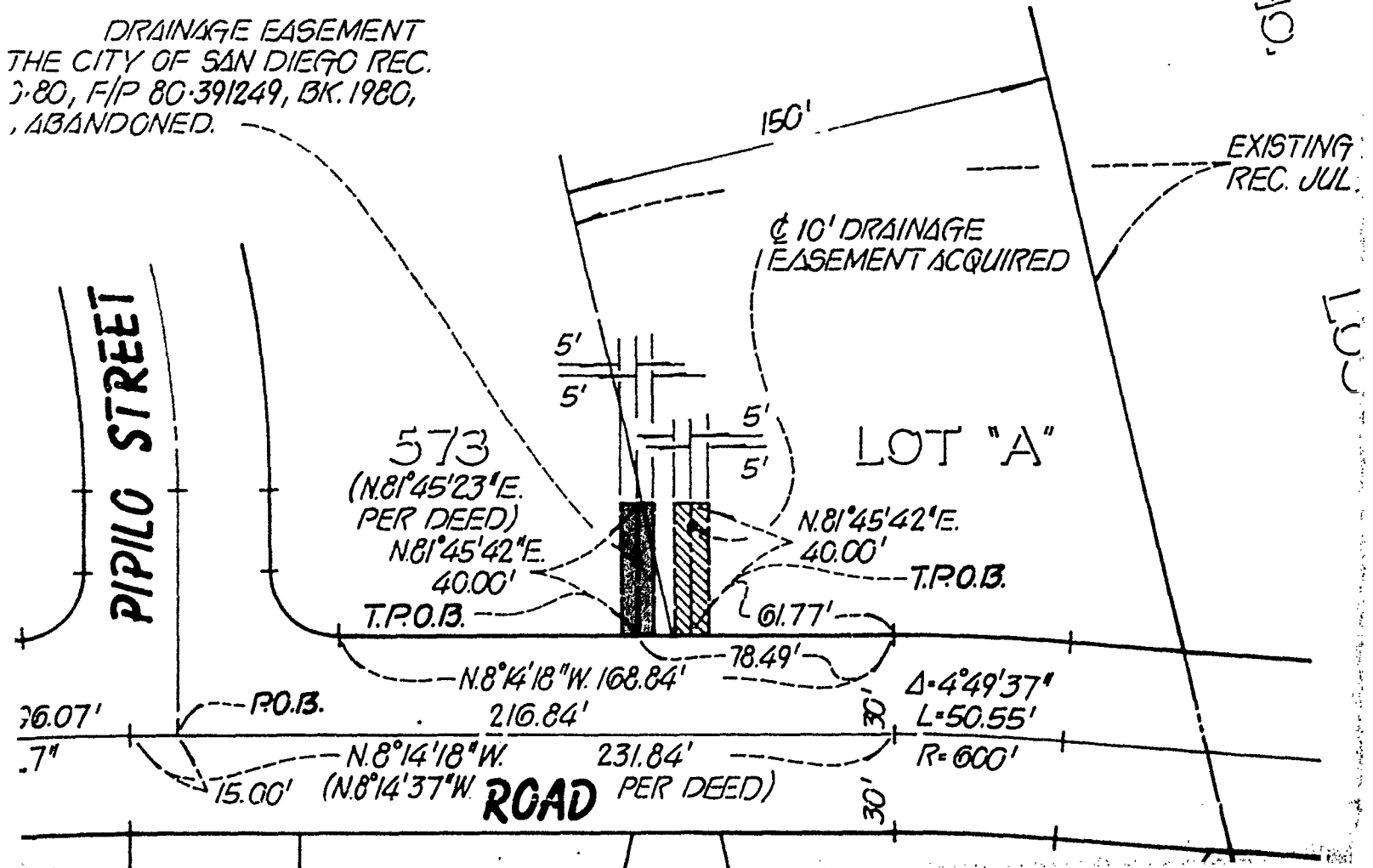

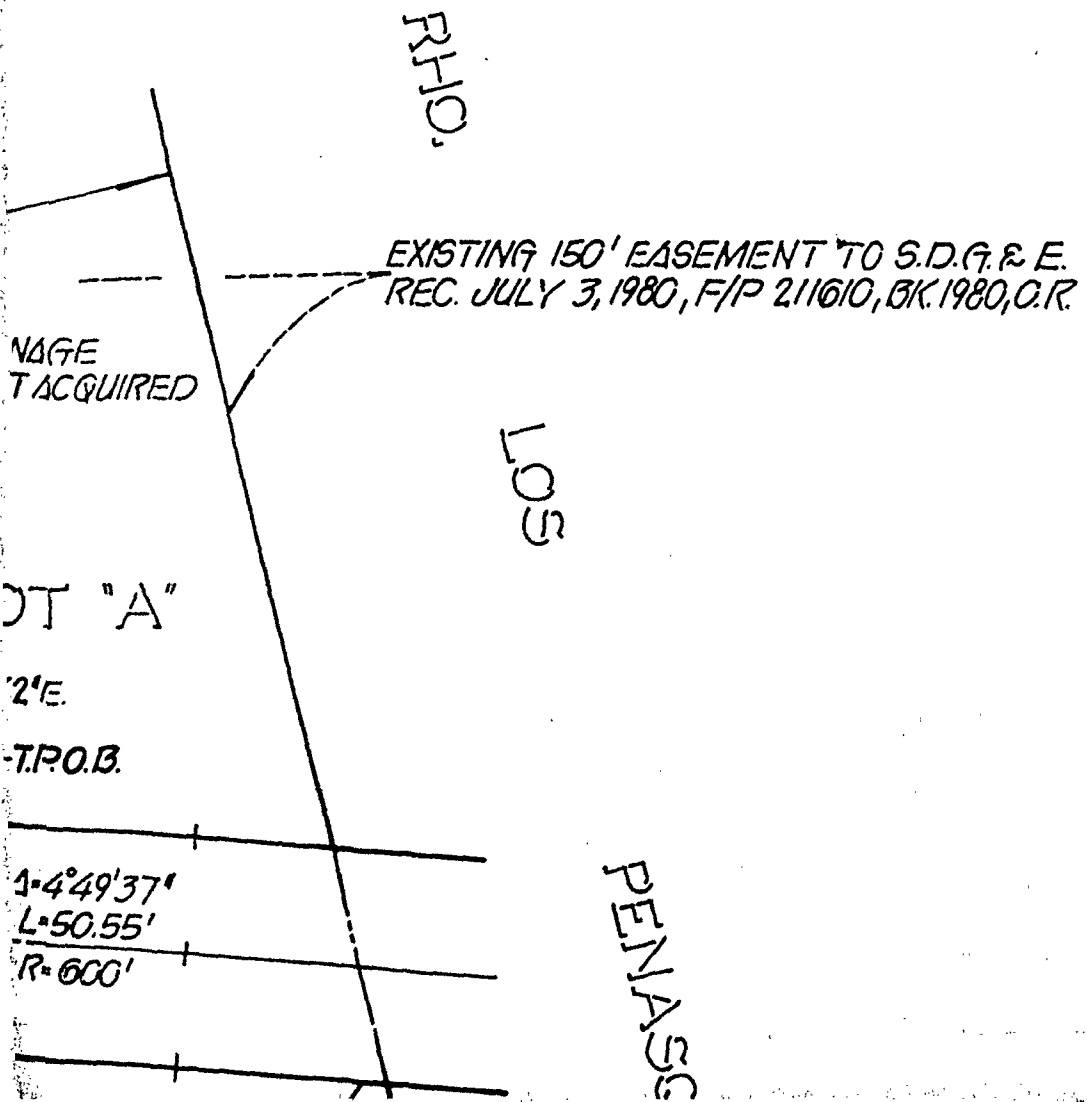

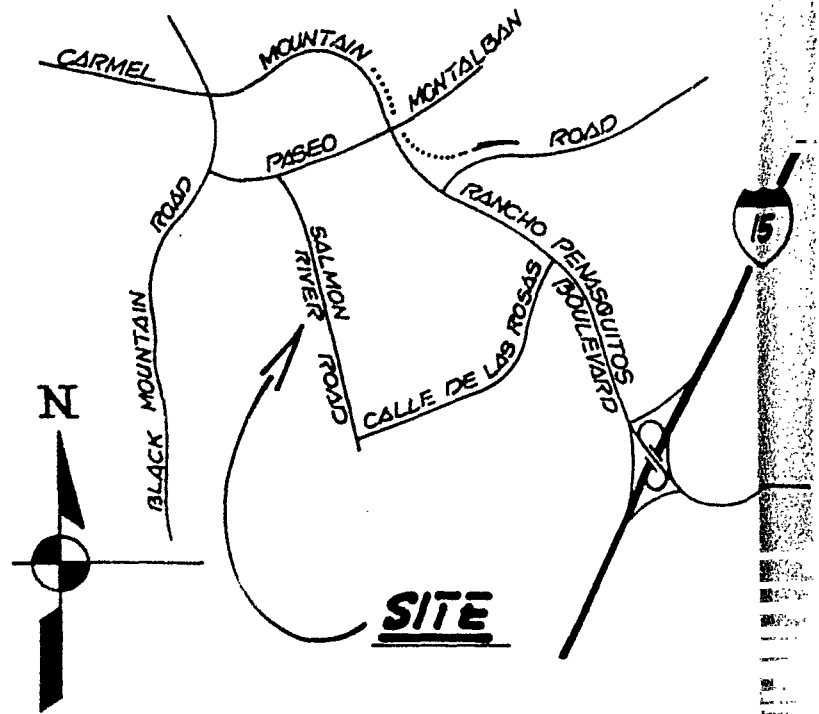
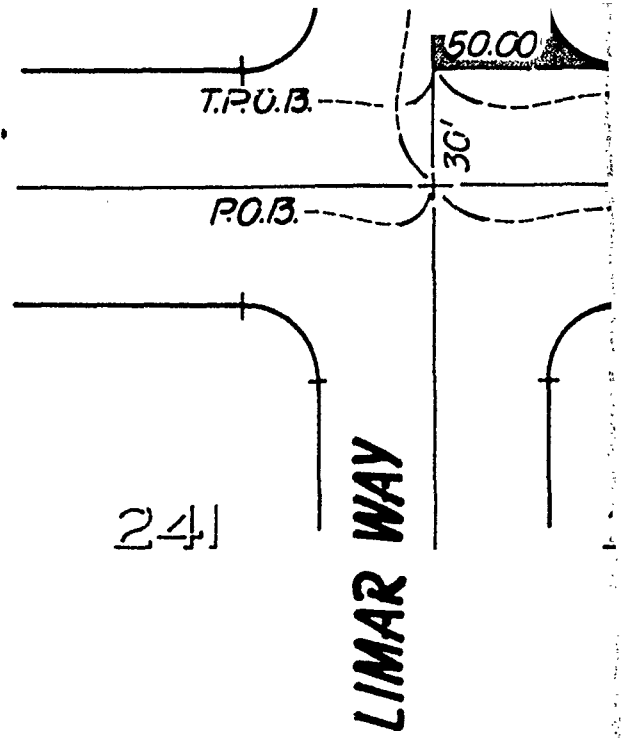

LOCATION

NOT TO

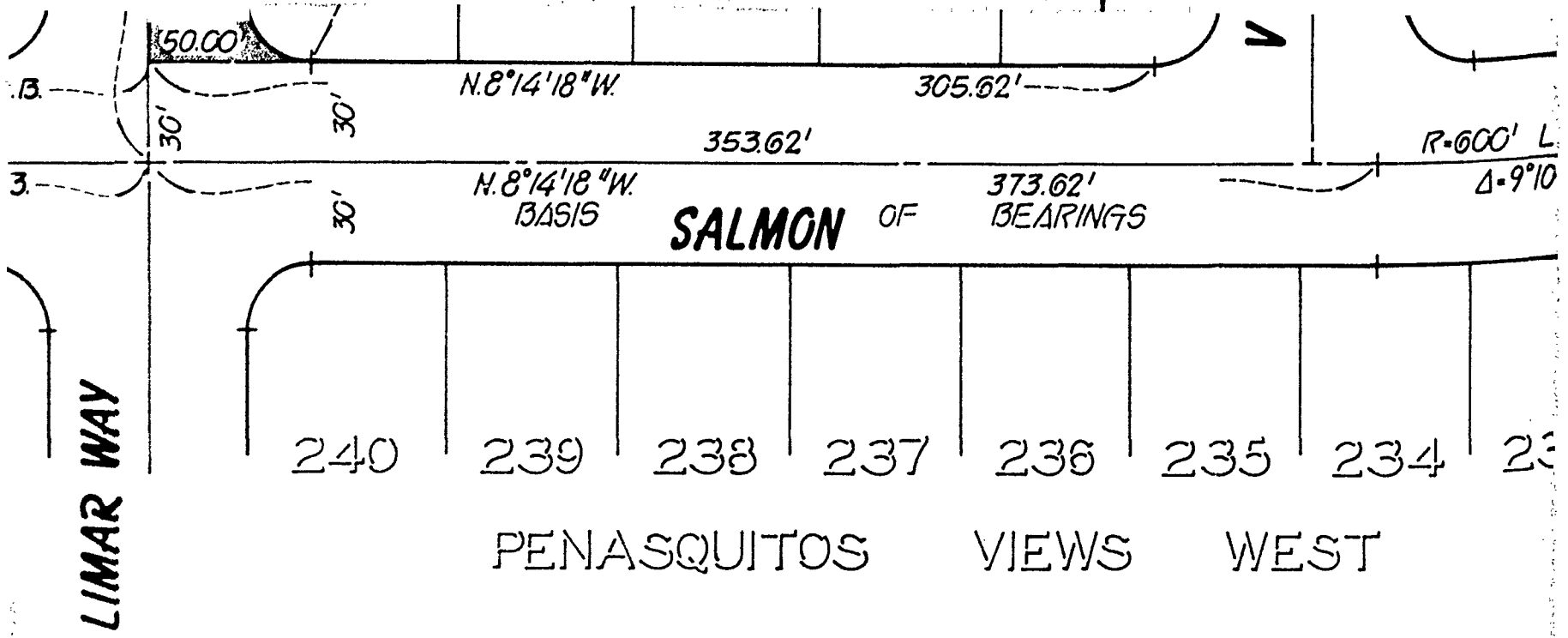

BASIS OF BEARINGS

THE BASIS OF BEARINGS FOR THIS RIVER ROAD PER PENASQUITOS PARK ACCORDING TO MAP THEREOF NO. 100

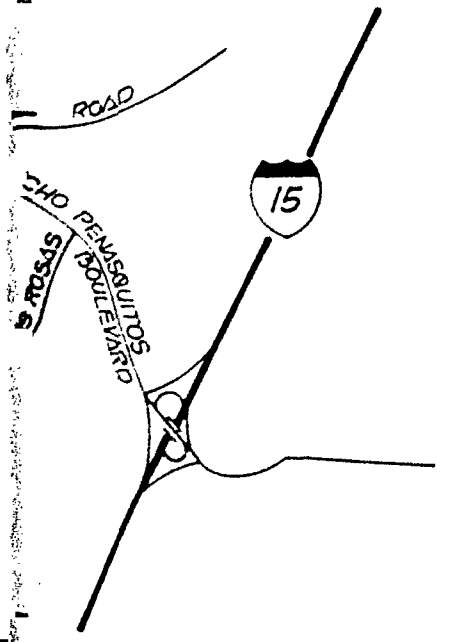

LOCATION MAP
NOT TO SCALE

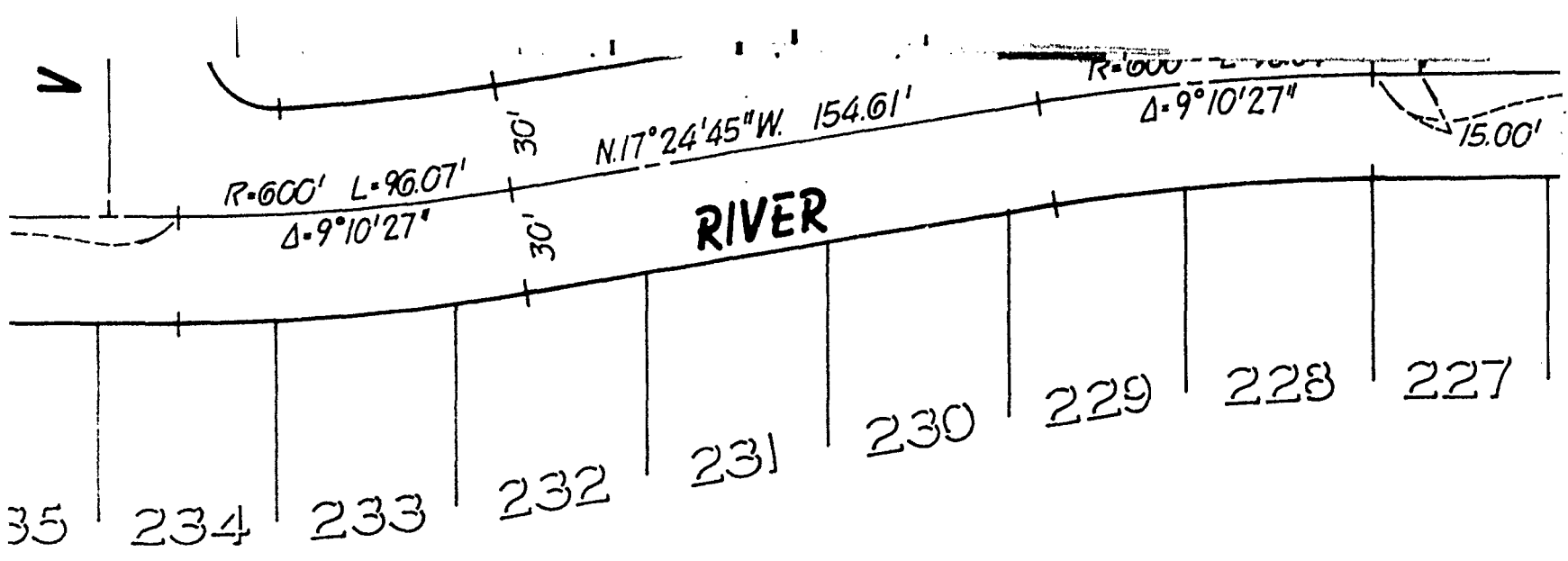

WEST

UNIT NO. 2

MAP NO.

IF BEARINGS

BEARINGS FOR THIS DRAWING IS THE C. OF SALMON
 PENASQUITOS PARK VIEW ESTATES UNIT NO. 3
 MAP THEREOF NO. 10043 I.E. N. 8°14'18" W.

LEGEND

 INDICATE
 INDICATE

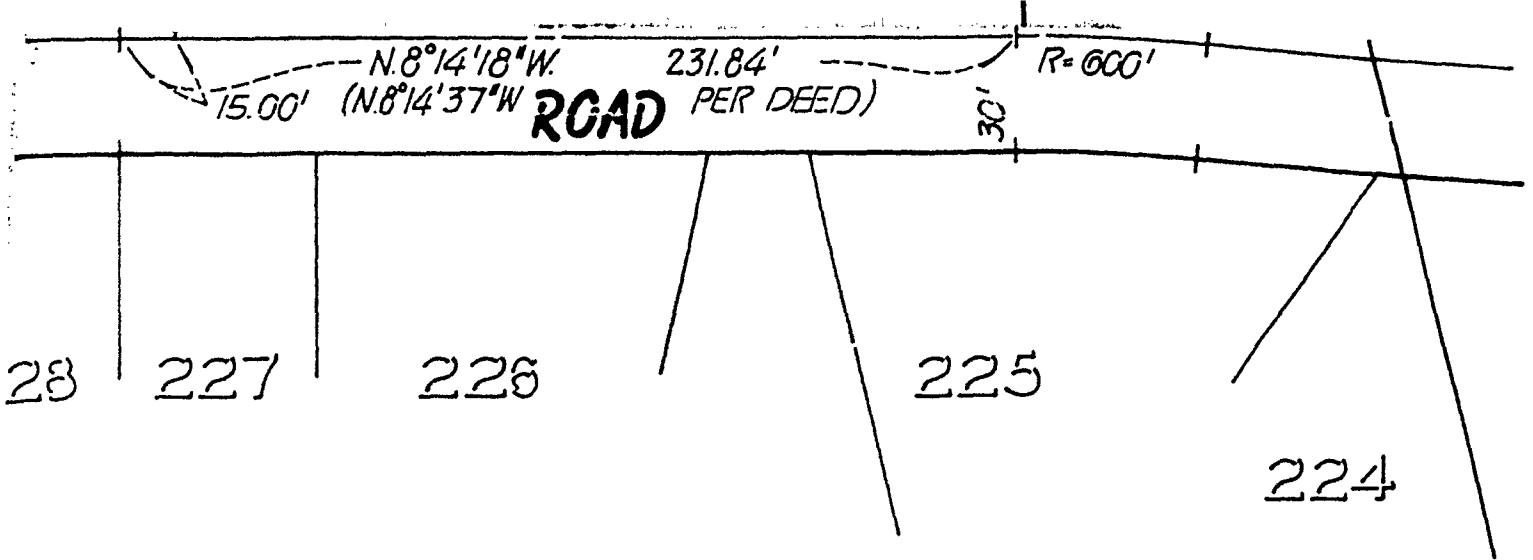

REFERENCE:

18886-D, 18714-11-



NO. 9898

ND

 INDICATES DRAINAGE EASEMENT ABANDONED
 INDICATES DRAINAGE EASEMENT ACQUIRED

REFERENCE DRAWINGS

D, 18714-11-D

ENGINEER OF WORK
Lyle F. Gabrielson 6.3.81
 LYLE F. GABRIELSON - R.C.E. 18174

PROJECT
RIC 5620 FF 3088 PIC
PLAN:
DRAIN: DRAIN: IN ADOLPH, LOT "A" OF F
CITY
<i>J. K. [Signature]</i> FOR
DESC...
ORIGINAL
CONTRACTOR
INSPECTOR

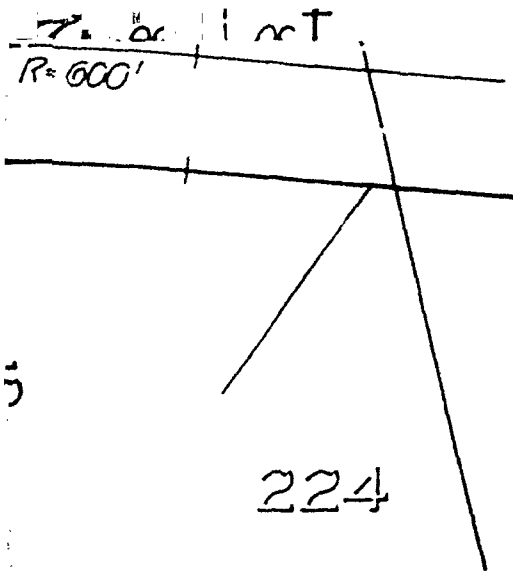

PENASQUITOS

DOCUMENT NO. RR-255455-2
 FILED DEC 7 1981
 OFFICE OF THE CITY CLERK
 SAN DIEGO, CALIFORNIA

PROJECT NO. <u>7198-A</u>		DATE <u>APR. 27, 1981</u>	
PRIVATE CONTRACT			
RICK ENGINEERING COMPANY			
5620 FRIARS ROAD, SAN DIEGO, CALIFORNIA 92110 (714) 291-0707 3088 PIO PICO DRIVE, CARLSBAD, CALIFORNIA 92008 (714) 729-4987			
PLANNERS • CIVIL ENGINEERS • LAND SURVEYORS			
DRAINAGE EASEMENT ABANDONMENT & DRAINAGE EASEMENT EXCHANGE			
IN ADOLPHIA STREET & LOTS 498 THRU 501 INCLUSIVE & LOT 573 & LOT "A" OF PENASQUITOS PARK VIEW ESTATES UNIT NO. 3 MAP NO 10043.			
CITY OF SAN DIEGO, CALIFORNIA		W.O. <u>T.M. 79-149</u>	
SHEET <u>1</u> OF <u>1</u> SHEET		NO. <u>71259</u>	
<i>[Signature]</i> FOR CITY ENGINEER		<u>7/14/81</u> DATE	
DESCRIPTION	BY	APPROVED	DATE FILMED
ORIGINAL	<u>V.G.W.</u>		
			<i>[Signature]</i> <u>7-10-81</u> CONTROL CERTIFICATION
			<u>282-1729</u> LAMBERT COORDINATES
CONTRACTOR _____		DATE STARTED _____	
INSPECTOR _____		DATE COMPLETED _____	
		19954-D	

WORK
[Signature] 6-3-81
 RIELSON ~ R.C.E.18174

EXHIBIT A

DEC 7 1981

Passed and adopted by the Council of The City of San Diego on
by the following vote:

Councilmen	Yeas	Nays	Not Present	Ineligible
Bill Mitchell	<input checked="" type="checkbox"/>	<input type="checkbox"/>	<input type="checkbox"/>	<input type="checkbox"/>
Bill Cleator	<input checked="" type="checkbox"/>	<input type="checkbox"/>	<input type="checkbox"/>	<input type="checkbox"/>
Susan Golding	<input checked="" type="checkbox"/>	<input type="checkbox"/>	<input type="checkbox"/>	<input type="checkbox"/>
Leon L. Williams	<input checked="" type="checkbox"/>	<input type="checkbox"/>	<input type="checkbox"/>	<input type="checkbox"/>
Ed Struikma	<input checked="" type="checkbox"/>	<input type="checkbox"/>	<input type="checkbox"/>	<input type="checkbox"/>
Mike Gotch	<input checked="" type="checkbox"/>	<input type="checkbox"/>	<input type="checkbox"/>	<input type="checkbox"/>
Dick Murphy	<input checked="" type="checkbox"/>	<input type="checkbox"/>	<input type="checkbox"/>	<input type="checkbox"/>
Lucy Killea	<input checked="" type="checkbox"/>	<input type="checkbox"/>	<input type="checkbox"/>	<input type="checkbox"/>
Mayor Pete Wilson	<input checked="" type="checkbox"/>	<input type="checkbox"/>	<input type="checkbox"/>	<input type="checkbox"/>

AUTHENTICATED BY:

PETE WILSON

Mayor of The City of San Diego, California.

(Seal)

CHARLES G. ABDELNOUR

City Clerk of The City of San Diego, California.

By *Charles G. Abdelnour* Deputy.

Office of the City Clerk, San Diego, California

Resolution Number 255456

Adopted DEC 7 1981