

AA

(O-2005-39)
(COR.COPY)

ORDINANCE NUMBER O- 19332 (NEW SERIES)

ADOPTED ON NOV 22 2004

AN ORDINANCE OF THE COUNCIL OF THE CITY OF SAN DIEGO AMENDING CHAPTER 10, ARTICLE 3, DIVISION 1, BY AMENDING SECTION 103.1703; AMENDING CHAPTER 11, ARTICLE 1, DIVISION 1, BY AMENDING SECTION 111.0105; AMENDING CHAPTER 11, ARTICLE 1, DIVISION 2, BY REPEALING SECTION 111.0203; AMENDING CHAPTER 11, ARTICLE 1, DIVISION 2, SECTIONS 111.0207 AND 111.0208; AMENDING CHAPTER 11, ARTICLE 2, DIVISION 3, BY AMENDING SECTION 112.0304; AMENDING CHAPTER 11, ARTICLE 2, DIVISION 5, BY AMENDING SECTIONS 112.0501 AND 112.0506; AMENDING CHAPTER 11, ARTICLE 3, DIVISION 1, BY AMENDING SECTION 113.0103; AMENDING CHAPTER 11, ARTICLE 3, DIVISION 2, BY ADDING SECTION 113.0231; AMENDING CHAPTER 11, ARTICLE 3, DIVISION 2 BY AMENDING SECTIONS 113.0249 AND 113.0252, AND 113.0270, 113.0273, AND 113.0276; AMENDING CHAPTER 12, ARTICLE 1, DIVISION 3, BY AMENDING SECTIONS 121.0302, 121.0309, AND 121.0312; AMENDING CHAPTER 12, ARTICLE 5, DIVISION 1, BY AMENDING SECTION 125.0120; AMENDING CHAPTER 12, ARTICLE 6, DIVISION 3, BY AMENDING SECTION 126.0303; AMENDING CHAPTER 12, ARTICLE 6, DIVISION 4, BY AMENDING SECTION 126.0402; AMENDING CHAPTER 12, ARTICLE 6, DIVISION 5, BY AMENDING SECTION 126.0502 AND 126.0504; AMENDING CHAPTER 12, ARTICLE 6, DIVISION 7, BY AMENDING SECTION 126.0704; AMENDING CHAPTER 12, ARTICLE 6, DIVISION 8, BY AMENDING SECTION 126.0804; AND AMENDING CHAPTER 12, ARTICLE 6, DIVISION 9, BY REPEALING SECTIONS 126.0901, 126.0902, 126.0903, 126.0904, 126.0905, 126.0906, AND 126.0907; AMENDING CHAPTER 12, ARTICLE 7, DIVISION 1, BY AMENDING SECTIONS 127.0104 AND 127.0106; AMENDING CHAPTER 12, ARTICLE 8, DIVISION 1, BY AMENDING SECTIONS 128.0103 AND 128.0104; AMENDING CHAPTER 12, ARTICLE 9, DIVISION 1, BY AMENDING SECTIONS 129.0104 AND 129.0112; AMENDING CHAPTER 12, ARTICLE 9, DIVISION 2, BY AMENDING SECTION 129.0214; AMENDING CHAPTER 12, ARTICLE 9, DIVISION 5, BY AMENDING SECTION 129.0506; AMENDING CHAPTER 12, ARTICLE 9, DIVISION 7, BY AMENDING SECTIONS 129.0702, 129.0703, 129.0710, AND BY ADDING SECTION 129.0715; AMENDING CHAPTER 13, ARTICLE 1,

DIVISION 2, BY AMENDING SECTION 131.0231 AND ADDING SECTION 131.0260; AMENDING CHAPTER 13, ARTICLE 1, DIVISION 4, BY AMENDING SECTIONS 131.0443, 131.0444, 131.0461, 131.0464, AND BY ADDING SECTION 131.0466; AMENDING CHAPTER 13, ARTICLE 1, DIVISION 5, BY AMENDING SECTION 131.0540; AMENDING CHAPTER 13, ARTICLE 2, DIVISION 12, BY AMENDING SECTION 132.1202; AMENDING CHAPTER 14, ARTICLE 1, DIVISION 10, BY AMENDING SECTION 141.1004; AMENDING CHAPTER 14, ARTICLE 2, DIVISION 1, BY ADDING SECTION 142.0150; AMENDING CHAPTER 14, ARTICLE 2, DIVISION 3, BY AMENDING SECTION 142.0340; AMENDING CHAPTER 14, ARTICLE 2, DIVISION 4, BY AMENDING SECTION 142.0402; AMENDING CHAPTER 14, ARTICLE 2, DIVISION 5, BY AMENDING SECTION 142.0560; AMENDING CHAPTER 14, ARTICLE 2, DIVISION 6, BY ADDING SECTION 142.0607; AMENDING CHAPTER 14, ARTICLE 2, DIVISION 6, BY AMENDING SECTIONS 142.0611 AND 142.0670; AMENDING CHAPTER 14, ARTICLE 2, DIVISION 8, BY AMENDING SECTION 142.0810; AMENDING CHAPTER 14, ARTICLE 2, DIVISION 12, BY AMENDING SECTION 142.1240; AMENDING CHAPTER 14, ARTICLE 3, DIVISION 1, BY AMENDING SECTIONS 143.0110, 143.0111, 143.0126, 143.0140, 143.0142; AND 143.0144; AMENDING CHAPTER 14, ARTICLE 3, DIVISION 3, BY AMENDING 143.0302; AMENDING CHAPTER 14, ARTICLE 4, DIVISION 2, BY AMENDING SECTION 144.0231; AMENDING CHAPTER 14, ARTICLE 4, DIVISION 2, BY ADDING SECTION 144.0233; AND AMENDING CHAPTER 14, ARTICLE 6, DIVISION 1, BY AMENDING SECTION 146.0106, ALL RELATING TO FOURTH UPDATE OF THE LAND DEVELOPMENT CODE.

BE IT ORDAINED, by the Council of the City of San Diego, as follows:

Section 1. That Chapter 10, Article 3, Division 17, of the San Diego

Municipal Code is amended by amending Section 103.1703, to read as follows:

§103.1703 **Applicable Regulations**

(a) **General Provisions**

(1) Where not otherwise specified in this division, the following chapters of the Land Development Code apply:

Chapter 11 (Land Development Procedures) - Chapter 14, Article 2,

Division 8 (Refuse and Recyclable Material Storage) [No change.]

Chapter 14, Article 2, Division 11 (Outdoor Storage, Display, and Activity Regulations);

Chapter 14, Article 2, Division 12 (Sign Regulation) through Chapter 14, Article 7 (Plumbing and Mechanical Regulations)

[No change.]

Where there is a conflict between the Land Development Code and this division, this division applies.

(2) through (6) [No change.]

(b) through (g) [No change.]

Section 2. That Chapter 11, Article 1, Division 1, of the San Diego Municipal Code is amended by amending Section 111.0105, to read as follows:

§111.0105 Hierarchy of Decision Making Authority

For purposes of the Land Development Code, the hierarchy of decision-making authority for acting upon an application for a permit, map, or other matter is as follows in descending order:

(a) and (b) [No change.]

(c) Hearing Officer; and

(d) City Staff

Section 3. That Chapter 11, Article 1, Division 2 is amended by repealing Section 111.0203.

Section 4. That Chapter 11, Article 1, Division 2, of the San Diego Municipal Code is amended by amending Section 111.0207, to read as follows:

§111.0207 Board of Building Appeals and Advisors

(a) [No change.]

(b) Appointment and Terms

(1) and (2) [No change.]

(3) The Building Official, the Chief of the Fire Department, and the City Attorney shall be ex officio members of the Board. The Planning Director shall be an ex officio member of the Board in matters pertaining to *Historical Buildings*.

(c) and (d) [No change.]

Section 5. That Chapter 11, Article 1, Division 2, of the San Diego Municipal Code is amended by amending Section 111.0208, to read as follows:

§111.0208 Board of Engineering Appeals and Advisors

(a) [No change.]

(b) Appointment and Terms

(1) [No change.]

(2) The Board of Engineering Appeals and Advisors shall be composed of the following:

(A) through (I) [No change.]

(J) The City Engineer, the Building Official, and the City Attorney, or their designated representatives, shall be ex officio members of the Board. The Planning Director shall be an ex officio member of the Board in matters pertaining to *historical buildings*.

(c) and (d) [No change.]

Section 6. That Chapter 11, Article 2, Division 3, of the San Diego Municipal Code is amended by amending Section 112.0304, to read as follows:

§112.0304 Posted Notice

[No change in text of first sentence.]

(a) through (c) [No change.]

(d) Maintaining Posted Notices. It is unlawful to deface, damage, move, or remove a notice posted in accordance with the applicable provisions of the Municipal Code.

Section 7. That Chapter 11, Article 2, Division 5, of the San Diego Municipal Code is amended by amending Section 112.0501, to read as follows:

§ 112.0501 Overview of Decision Process

[No change in text of first paragraph.]

**Diagram 112-05A
Decision Processes with Notices**

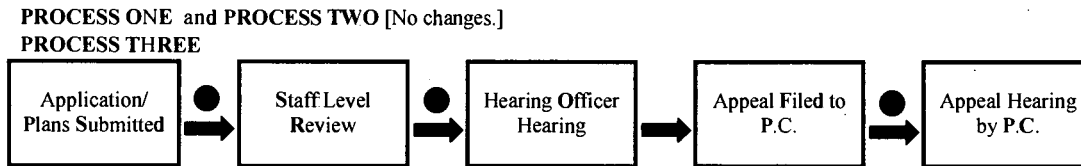

PROCESS FOUR and PROCESS FIVE [No changes.]

Section 8. That Chapter 11, Article 2, Division 5, of the San Diego Municipal Code is amended by amending Section 112.0506, to read as follows:

§112.0506 Process Three Appeals

The Hearing Officer's decision may be appealed to the Planning Commission, as specified in Chapter 12, Article 6 for the type of *development* and review required.

An appeal from a Hearing Officer's decision that involves applications consolidated in accordance with Section 112.0103 shall be heard by the Planning Commission. An appeal from a Process Three decision shall be made in the following manner.

(a) through (c) [No change.]

(d) Scheduling the Appeal Hearing. The appeal hearing before the Planning Commission shall be held, or the City Manager shall set a date for the appeal hearing, no later than 30 calendar days after the date on which the application

for an appeal is filed. The appeal hearing shall be noticed in accordance with Section 112.0308.

- (e) Power to Act on Appeal. After the conclusion of the public hearing, the Planning Commission or may affirm, reverse, or modify the decision being appealed.

Section 9. That Chapter 11, Article 3, Division 1, of the San Diego Municipal Code is amended by amending Section 113.0103, to read as follows:

§113.0103 Definitions

Abutting property through Development permit [No change.]

Disabled Person, pursuant to the Fair Housing Amendments Act of 1988, means any person who has a physical or mental impairment that substantially limits one or more major life activities; anyone who is regarded as having such impairment; or anyone who has a record of such impairment.

Dormer through Internally illuminated sign [No change.]

Kitchen means an area used or designed to be used for the preparation of food which includes facilities to aid in the preparation of food such as a sink, a refrigerator and stove, a range top or oven.

Land use plans through Public utility [No change.]

Reasonable Accommodation, pursuant to the Fair Housing Amendments Acts of 1988 and the California Fair Employment and Housing Act, means accommodations necessary to afford *disabled persons* an equal opportunity to use and enjoy a *dwelling unit*.

Reclamation through Yard [No change.]

Section 10. That Chapter 11, Article 3, Division 2, of the San Diego Municipal Code is amended by adding Section 113.0231, to read as follows:

§113.0231 Determining Proposed Grade

Proposed grade is the ground elevation that will exist when all proposed *development* has been completed. *Proposed grade* does not include pools and does not include *basements* where, at any point adjacent to the *basement*, the vertical distance between *existing grade* or *proposed grade*, whichever is lower, and the *finish-floor* elevation immediately above is 2 feet, 6 inches or less, as shown in Diagram 113-02H. If a *basement* contains multiple *floors*, the *finish-floor* elevation of the highest *basement floor* shall be used to determine *proposed grade*.

Diagram 113-02H

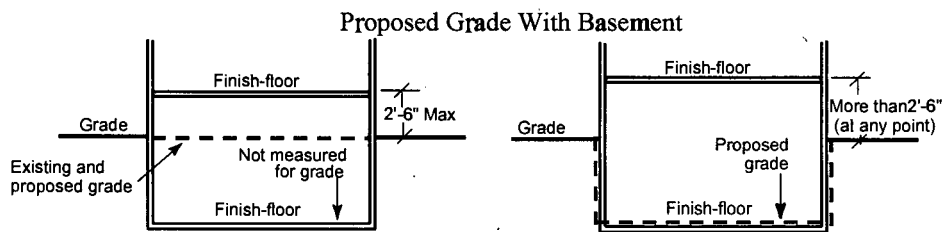

Change to Diagram 113-02H also includes text change from “2’-6” max to “2’-6” or less”

Section 11. That Chapter 11, Article 3, Division 2, of the San Diego Municipal Code is amended by amending Section 113.0249, to read as follows:

§113.0249 Determining Setback Line

- (a) and (b) [No change.]
- (c) When a side *setback* is allowed to observe the minimum dimensions as described in Section 131.0443(a)(3)(Setback Requirements in Residential Zones) all additions to the primary *structure* thereafter shall maintain that established side *setback*.

Section 12. That Chapter 11, Article 3, Division 2, of the San Diego Municipal Code is amended by amending Section 113.0252, to read as follows:

§113.0252 Measuring Setbacks

- (a) [No change.]
- (b) Those portions of *underground parking structures, first stories, and basements* that are above *grade* are subject to *setback* requirements. *Structures* located completely underground are exempt from the *setback* requirements except where the *structure* would conflict with the required landscape and irrigation.

Section 13. That Chapter 11, Article 3, Division 2, of the San Diego Municipal Code is amended by amending Sections 113.0270, 113.0273, and 113.0276, to read as follows:

§113.0270 Measuring Structure Height

Structure height is measured in accordance with the following.

- (a) *Structure Height of Buildings and Structures Other Than Fences, Retaining Walls, or Signs*
 - (1) through (7) [No change.]
 - (8) **When a pool is located within 5 feet of the *structure*, the overall *structure height* is measured as noted in Section 113.0270(a)(5), except that *proposed grade* shall not include the pool. This is illustrated in Diagram 113-0200.**

Diagram 113-0200

Overall Structure Height With Pool

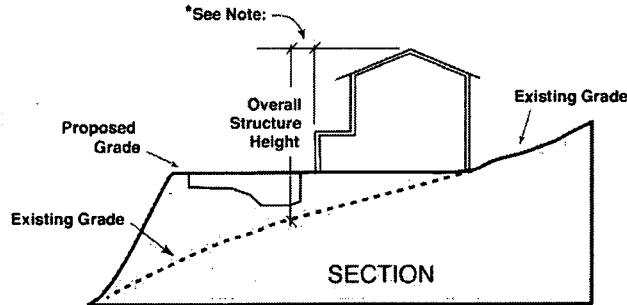
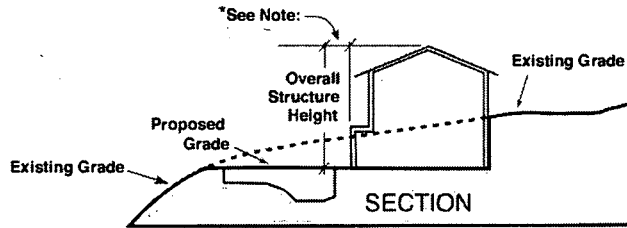

* Structure height is measured from the lowest point of existing grade or proposed grade within 5 feet of the structure's perimeter.

(b) *Structure Height of Fences, Walls, and Retaining Walls*

(1) *Fence and Wall Height*

- (A) No height of any portion of a *fence* or wall is measured from the lowest grade abutting the *fence* or wall to the top of the *fence* or wall, except that the height of a *fence* or wall on top of a retaining wall is measured from *grade* on the higher side of the *retaining wall*, as shown in Diagram 113-02PP.

Diagram 113-02PP
Height of Fence or Wall on Retaining Wall

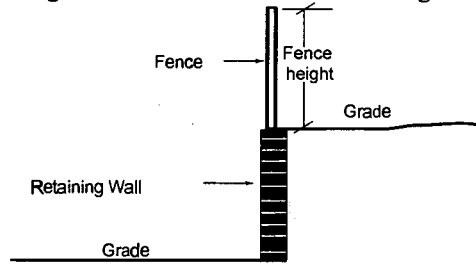

(B) [No change.]

(2) *Retaining Wall Height*

The height of a *retaining wall* is measured from *grade* on the lower side of the *retaining wall* to the top of the *retaining wall*, as shown in Diagram 113-02QQ.

Diagram 113-02QQ
Retaining Wall Height

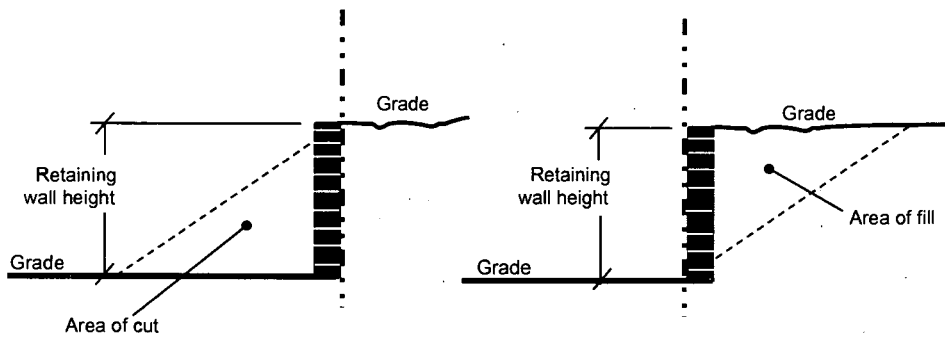

(c) [No change.]

§113.0273 Measuring Visibility Area

The *visibility area* is a triangular portion of a premises formed by drawing one line perpendicular to and one line parallel to the *property line* or *public right-of-way* for a specified length and one line diagonally joining the other two lines, as shown in Diagram 113-02RR. No *structures* may be located within a *visibility area* unless otherwise provided by the applicable zone or the regulations in Chapter 14, Article 2 (General Development Regulations).

(a) through (d) [No change.]

**Diagram 113-02RR
Visibility Area**

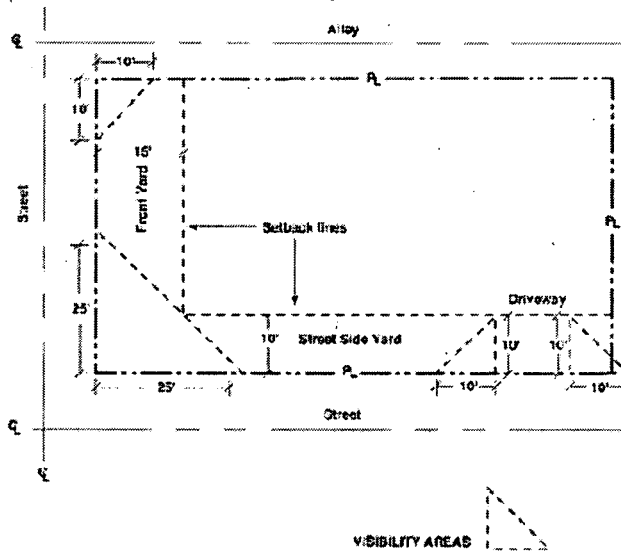

§113.0276 Determining Yards

(a) *Yards* are determined in the hierarchy described below and shown in Diagram

113-02SS:

(1) through (4) [No change.]

**Diagram 113-02SS
Yards**

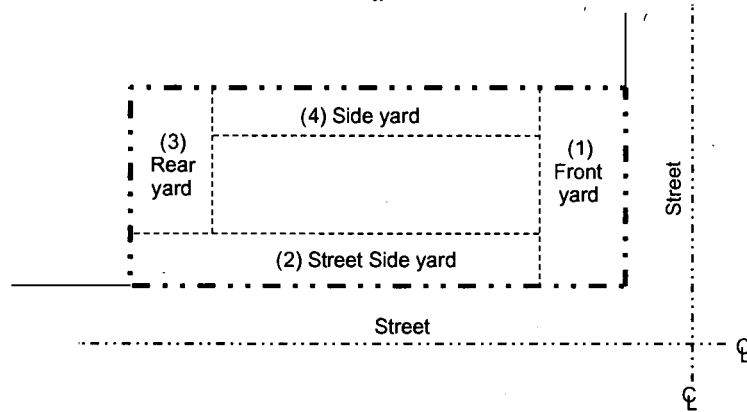

(b) and (c) [No change.]

Section 14. That Chapter 12, Article 1, Division 3, of the San Diego Municipal Code is amended by amending Section 121.0302, to read as follows:

§121.0302 Required Compliance with the Land Development Code

- (a) [No change.]
- (b) [No change in text of first sentence.]
 - (1) To erect, place, construct, convert, establish, alter, use, enlarge, repair, move, remove, equip, maintain, improve, occupy, or demolish any *structures*;
 - (2) through (4) [No change.]
- (c) through (i) [No change.]

Section 15. That Chapter 12, Article 1, Division 3, of the San Diego Municipal Code is amended by amending Section 121.0309, to read as follows:

§121.0309 Procedure for Issuing a Stop Work Order

- (a) [No change.]
- (b) City Attorney Review. Where a permit has been issued, the City Attorney shall approve all Stop Work Orders before issuance except where irreparable harm is imminent so as to warrant an emergency Stop Work Order. Where emergency circumstances exist, the order shall be issued according to the discretion of the City Manager or designated Code Enforcement Official with immediate subsequent review by the City Attorney.
- (c) Appeal of Order. A Stop Work Order may be appealed to the City Manager. When the alleged violation involves the Building, Electrical, Plumbing, or Mechanical Regulations, the appeal shall be reviewed by the Building Official. All other appeals shall be reviewed by the Development Services Director. The decision maker will provide informal rapid access for appellants in these matters in order to minimize unnecessary disruption of construction activities.

Section 16. That Chapter 12, Article 1, Division 3, of the San Diego Municipal Code is amended by amending Section 121.0312, to read as follows:

§121.0312 Restoration and Mitigation as a Remedy

- (a) [No change.]
- (b) The City Manager shall order the restoration of *grading* undertaken without a permit, unless technically infeasible. The restoration shall be conducted in accordance with Section 142.0150. No further permits for the *premises* shall be processed until the restoration has been completed and specified performance criteria have been met as required by the City.
- (c) Any restoration or mitigation imposed by the City Manager or Building Official shall be at the sole cost of the responsible person.
- (d) Mitigation may be appropriate where the City Manager determines that restoration of the *premises* or adjacent site to its pre-existing condition is not feasible or that irreparable damage has been done to the *premises*, or *historical resources*.
- (e) Mitigation may include the purchase or exchange of like-kind real property or *structures* of a similar or greater quality and value, or other appropriate measures.
- (f) The City Manager or Building Official may require a combination of restoration and mitigation of the *structure* or *premises* if warranted by the circumstances.
- (g) The City Manager or Building Official may promulgate additional administrative guidelines and regulations to implement and clarify the authority to require restoration and mitigation.

Section 17. That Chapter 12, Article 5, Division 1, of the San Diego Municipal Code is amended by amending Section 125.0120, to read as follows:

§125.0120 When a Map Waiver May Be Requested

[No change in the first paragraph.]

(a) [No change.]

(b) Condominium Projects.

(1) The *Subdivider* may request a waiver of the requirement to file a *tentative map* and *parcel map* or *final map* for the construction of a new condominium project on a single parcel that was previously mapped and monumented in a manner satisfactory to the City Engineer in accordance with Subdivision Map Act Section 66428(b);
or

(2) The *Subdivider* may request a waiver of the requirement to file a *tentative map* and *parcel map* for a *condominium conversion* project creating four or fewer condominium units.

(c) [No change.]

Section 18. Chapter 12, Article 6, Division 3, of the San Diego Municipal Code, is hereby amended by amending Section 126.0303, to read as follows:

§126.0303 When a Conditional Use Permit Is Required

[No change to the paragraph.]

(a) Conditional Use Permits Decided by Process Three [No change.]

(b) Conditional Use Permits Decided by Process Four

Botanical gardens and arboreums through Nightclubs and bars over 5,000 square feet in size [No change.]

Privately operated recreations facilities over 40,000 square feet in size

Residential care facilities for 13 or more persons through Wrecking and dismantling of motor vehicles [No change.]

(c) Conditional Use Permits Decided by Process Five [No change.]

Section 19. That Chapter 12, Article 6, Division 4, of the San Diego Municipal Code is amended by amending Section 126.0402, to read as follows:

§126.0402 When a Neighborhood Development Permit Is Required

(a) through (i) [No change.]

(j) A Neighborhood Development Permit is required for *development* requesting deviations for the purposes of *reasonable accommodations* on developed *premises* as described in Sections 132.0466.

(k) A Neighborhood Development Permit is required for construction of a privately owned *structure* proposed in the *public right-of-way* dedicated for a *street* or an *alley*, where the *applicant* is the *record owner* of the underlying fee title as described in Sections 129.0710(a) and 129.0710(b)(2).

Section 20. That Chapter 12, Article 6, Division 5, of the San Diego Municipal Code is amended by amending Section 126.0502, to read as follows:

§126.0502 When a Site Development Permit Is Required

(a) through (c) [No change.]

(d) A Site Development Permit decided in accordance with Process Four is required for the following types of development.

(1) through (5) [No change.]

(6) Any *encroachment* or object which is erected, placed, constructed, established or maintained in the *public right-of-way* when the *applicant* is not the *record owner* of the property on which the

proposed *encroachment* will be located in accordance with Section 129.0710(b).

(e) [No change.]

Section 21. That Chapter 12, Article 6, Division 5, of the San Diego Municipal Code is amended by amending Section 126.0504, to read as follows:

§126.0504 Findings for Site Development Permit Approval

A Site Development Permit may be approved or conditionally approved only if the decision maker makes all of the *findings* in Section 126.0504(a) and the supplemental *findings* in Section 126.0504(b) through (n) that are applicable to the proposed *development* as specified in this Section.

(a) through (m) [No change.]

(n) Supplemental Findings- *Public Right-of-Way* Encroachments.

A Site Development Permit in accordance with Section 126.0502(d)(6) for any *encroachment* or object which is erected, placed, constructed, established or maintained in the *public right-of-way* when the *applicant* is not the *record owner* of the property on which the proposed *encroachment* will be located may be approved or conditionally approved only if the decision maker makes the following supplemental *findings* in addition to the *findings* in Section 126.0504(a):

- (1) The proposed *encroachment* is reasonably related to public travel, or benefits a public purpose, or all *record owners* have given the applicant written permission to maintain the *encroachment* on their property;
- (2) The proposed *encroachment* does not interfere with the free and unobstructed use of the *public right-of-way* for public travel;

- (3) The proposed *encroachment* will not adversely affect the aesthetic character of the community; and
- (4) The proposed *encroachment* does not violate any other Municipal Code provisions or other local, state, or federal law.

Section 22. That Chapter 12, Article 6, Division 7, of the San Diego Municipal Code is amended by amending Section 126.0704, to read as follows:

§126.0704 Exemptions from a Coastal Development Permit

[No change in text of first sentence.]

- (a) Improvements to existing *structures* are exempt, except if the improvements involve any of the following:

- (1) through (4) [No change.]

- (5) The demolition or removal of 50 percent or more of the exterior walls of the existing structure.

- (6) through (9) [No change.]

- (b) through (i) [No change.]

Section 23. That Chapter 12, Article 6, Division 8, of the San Diego Municipal Code is amended by amending Section 126.0804, to read as follows:

§126.0804 Decision Processes for a Variance

A decision on an application for a variance shall be made in accordance with Process Three. The decision may be appealed to the Planning Commission unless otherwise specified by the Land Development Code.

Section 24. That Chapter 12, Article 6, Division 9, of the San Diego Municipal Code is amended by repealing Sections 126.0901, 126.0902, 126.0903, 126.0904, 126.0905, 126.0906 and 126.0907.

Section 25. That Chapter 12, Article 7, Division 1, of the San Diego Municipal Code is amended by amending Section 127.0104, to read as follows:

§127.0104 Maintenance, Repair, or Alteration of Previously Conforming Structures

(a) and (b) [No change.]

Section 26. That Chapter 12, Article 7, Division 1, of the San Diego Municipal Code is amended by amending Section 127.0106, to read as follows:

§127.0106 Expansion or Enlargement of Previously Conforming Structures

(a) through (c) [No change.]

(d) Within the Coastal Overlay Zone, if the proposal involves the demolition or removal of 50 percent or more of the exterior walls of an existing structure, the previously conforming rights are not retained for the new structure.

Section 27. That Chapter 12, Article 8, Division 1, of the San Diego Municipal Code is amended by amending Section 128.0103, to read as follows:

§128.0103 Powers and Duties of the Development Services Director in Implementing Environmental Quality Procedures

The Development Services Director shall be responsible for implementing this article.

(a) The Development Services Director shall have the following powers as required for all projects or activities as defined by CEQA, whether proposed by private *applicants*, the City, or other public agencies:

(1) through (8) [No change.]

(b) The Development Services Director shall establish and maintain that degree of independence in the performance of these functions and duties as will assure the City Council, the City Manager, the Planning Commission, and the people of the City of San Diego that the review and analysis of the

environmental consequences of projects, are in accordance with CEQA, are independent and wholly objective, and are not prepared for the purpose of either supporting or detracting from any project, plan, or position, whether advanced by the City, any other governmental agency, or private interest.

Section 28. That Chapter 12, Article 8, Division 1, of the San Diego Municipal Code is amended by amending Section 128.0104, to read as follows:

§128.0104 Authority to Require Mitigation and Monitoring Programs

When the conditions of a project approval require mitigation and monitoring, the City Manager and the Development Services Director are responsible for promulgating mitigation and monitoring standards and guidelines for public and private projects consistent with the requirements of CEQA section 21081.6. The Development Services Director or City Manager may require appropriate surety instruments or bonds from private project *applicants* to ensure the long term performance or implementation of required mitigation measures or programs. The City is authorized to recover its costs to offset the salary, overhead, and expenses for City personnel and programs to monitor qualifying projects.

Section 29. That Chapter 12, Article 9, Division 1, of the San Diego Municipal Code is amended by amending Section 129.0104, to read as follows:

§129.0104 Construction Permit Authorities

- (a) [No change.]
- (b) The powers and duties of the City Engineer with respect to *construction permits* are as follows:
 - (1) [No change.]
 - (2) To review applications for Grading Permits and Public Right-of-Way Permits including plans, specifications, and other data to determine if

an application is in compliance with the Municipal Code, adopted City standards, and engineering standards of practice.

(3) through (11) [No change.]

Section 30. That Chapter 12, Article 9, Division 1, of the San Diego Municipal Code is amended by amending Section 129.0112, to read as follows:

§129.0112 Responsibilities of Permittee or Authorized Agent Regarding Inspections

(a) through (d) [No change.]

(e) One set of the approved plans, permits and specifications shall be kept on the site of the *structure* or work at all times during which work authorized by those plans is in progress, and shall be made available to City officials upon request.

Section 31. That Chapter 12, Article 9, Division 2, of the San Diego Municipal Code is amended by amending Section 129.0214, to read as follows:

§129.0214 Requirements for Approved Plans

(a) [No change.]

(b) Except as required by Sections 19850 and 19851 of the Health and Safety Code, the building official shall retain one set of approved plans, specification and computations for a period of not less than 90 calendar days from the date of completion of the work authorized by those plans, after which time the building official may, at his or her discretion, either dispose of the copies or retain them as a part of the permanent files of the Development Services Department.

Section 32. That Chapter 12, Article 9, Division 5, of the San Diego Municipal Code is amended by amending Section 129.0506, to read as follows:

§129.0506 Issuance of a Demolition/Removal Permit

- (a) A Demolition/Removal Permit may be issued after all required approvals and documentation have been obtained and the required fees have been paid. In addition to plan check approvals, other documentation may be required before permit issuance, in conformance with the requirements of the Land Development Code, or the laws or requirements of other local, state, or federal jurisdictions. A Demolition/Removal Permit shall not be issued for a *development* that requires a *development permit* or for which a *development permit application* has been submitted until the *development permit* has been issued or has been withdrawn, where not otherwise required. Documentation of required insurance and surety shall be presented in accordance with Sections 129.0508 and 129.0509.
- (b) [No change.]

Section 33. That Chapter 12, Article 9, Division 7, of the San Diego Municipal Code is amended by amending Section 129.0702, to read as follows:

§129.0702 When a Public Right-of-Way Permit Is Required

- (a) A Public Right-of-Way Permit is required for the following unless otherwise exempt under Section 129.0703:
- (1) [No change.]
 - (2) The construction of privately owned *structures* or facilities in the *public right-of-way*;
 - (3) [No change.]
 - (4) The planting of any tree, shrub, or plant greater than 30 inches in height in the *public right-of-way*; where not otherwise covered by a

Street Tree Permit per Chapter 6, Article 2, Division 6 (Street Planting).

(b) [No change.]

Section 34. That Chapter 12, Article 9, Division 7, of the San Diego Municipal Code is amended by amending Section 129.0703, to read as follows:

§129.0703 Exemptions from Requirement for a Public Right-of-Way Permit

Exemption from the Public Right-of-Way permit requirements does not authorize any work to be done in violation of the provisions of the *public right-of-way* regulations or other applicable local or state regulations. A Public Right-of-Way Permit is not required for the following work:

(a) [No change.]

(b) The installation of landscape in the *parkway* that is less than 30 inches high and will be maintained by the fronting property owner or where otherwise covered by a Street Tree Permit per Chapter 6, Article 2, Division 6 (Street Planting).

Section 35. That Chapter 12, Article 9, Division 7, of the San Diego Municipal Code is amended by amending Section 129.0710, to read as follows:

§129.0710 How to Apply for a Public Right-of-Way Permit

An application for a Public Right-of-Way Permit shall be submitted in accordance with Sections 112.0102 and 129.0105. The submittal requirements for Public Right-of-Way Permits are listed in the Land Development Manual. A *development permit* or other discretionary approval is required prior to issuance of a Public Right-of-Way Permit for the following:

(a) If the proposed *encroachment* involves construction of a privately owned *structure* or facility into the *public right-of-way* dedicated for a *street* or an

alley, and where the *applicant* is the *record owner* of the underlying fee title, a Neighborhood Development Permit is required in accordance with Section 126.0402 (k) except for the following:

- (1) Private *hardscape* improvements in the *public right-of-way* including ramps required to accommodate required access for *disabled persons*;
 - (2) Fences or walls that meet the following criteria:
 - (A) There is no present use for the subject *public right-of-way*;
 - (B) The proposed *encroachment* is consistent with the underlying zone, city standards, and policies:
 - (C) The proposed *encroachment* shall be 3 feet or less in height.
 - (3) The *encroachment* is permitted under Chapter 6, Article 2, Division 11 (Utilities) or as a private underground utility service to the *applicant's* property.
 - (4) The *encroachment* is permitted under Section 141.0619(b) (Pushcarts).
 - (5) The *encroachment* is permitted under Chapter 6, Article 2, Division 10 (Newsracks).
 - (6) The *encroachment* is permitted under Section 141.0621 (Sidewalk Cafes).
 - (7) Temporary monitoring wells in the *public right-of-way*
- (b) If the proposed *encroachment* is erected, placed, constructed, established or maintained in the *public right-of-way* when the applicant is not the *record owner* of the property on which the *encroachment* will be located, a Site

Development Permit is required in accordance with Section 126.0502(d)(6), except for the following:

- (1) *Encroachments* listed in Section 129.0710(a)(4) through (7)
- (2) Underground utility connections to a public main shall require a Neighborhood Development Permit in accordance with Section 126.0402(k).
- (c) If the proposed *encroachment* includes underground or overhead structures which extend into the *public right-of-way* farther than the ultimate curb line, or other *encroachments* which, in the opinion of the City Manager, are of sufficient public interest to warrant City Council approval, the item shall be scheduled for early consideration by the City Council in accordance with Council Policy 600-16, prior to the issuance of a Public Right-of-Way Permit.

Section 36. That Chapter 12, Article 9, Division 7, of the San Diego Municipal Code is amended by adding Section 129.0715, to read as follows:

§129.0715 Encroachment Maintenance and Removal Agreement

- (a) An Encroachment Maintenance and Removal Agreement is required for any privately owned facilities or *structures* in the *public right-of-way* constructed and maintained by the property owner subject to the following:
 - (1) The *encroachment* shall be installed and maintained in a safe and sanitary condition at the sole cost, risk and responsibility of the owner and successors in interest and shall not adversely affect the public's health, safety or general welfare.
 - (2) The property owner shall agree to indemnify the City with an indemnification agreement satisfactory to the City Manager and City Attorney.

- (3) The property owner must agree to remove or relocate the *encroachment* within 30 days after notice by the City Engineer or the City Engineer may cause such work to be done, and the costs thereof shall be a lien upon said land, or the property owner agrees to an equivalent to the requirement for removal as determined by the City Engineer.
- (4) For *structures* encroaching over or under the *public right-of-way*, the property owner agrees to provide an alternate *right-of-way* or to relocate any existing or proposed City facility to a new alignment, all without cost or expense to the City, whenever it is determined by the City Engineer that any existing or proposed City facility cannot be economically placed, replaced, or maintained due to the presence of the encroaching *structure*.
- (5) Whatever rights and obligations were acquired by the City with respect to the *rights-of-way* shall remain and continue in full force and effect and shall in no way be affected by the City's grant of permission to construct and maintain the encroaching *structure*.
- (6) Except as provided in Section 129.0715(a)(7), the property owner shall maintain a policy of \$1 million liability insurance, satisfactory to the City Engineer, to protect the City from any potential claims which may arise from the *encroachment*.
- (7) The property owner of an *encroachment* serving a *single dwelling unit* shall maintain a policy of \$500,000 liability insurance, for *encroachments* serving a *single dwelling unit* satisfactory to the City

Engineer to protect the City from any potential claims which may arise from the *encroachments*.

- (8) In the event the City is required to place, replace, or maintain a *public improvement* over which the property owner has constructed an encroaching *structure*, the property owner shall pay the City that portion of the cost of placement, replacement, or maintenance caused by the construction, or existence of the owner's permanent encroaching *structure*.
- (9) The property owner shall pay the City for all the cost of placing, replacing, or maintaining a *public improvement* within a *public right-of-way* when the City's facility has failed as a result of the construction or existence of the owner's encroaching *structure*.
- (10) The costs of placing, replacing, or maintaining the *public improvement* shall include the cost of obtaining a necessary alternate easement.
- (11) The property owner shall pay the City or public utility for all cost of relocating, replacing, or protecting a facility within the *public right-of-way* when such relocation, replacement, or protection results from the construction of the *encroachment*.
- (12) Encroachment Maintenance and Removal Agreements for approved *encroachments* shall be recorded in the office of the County Recorder.

Section 37. That Chapter 13, Article 1, Division 2, of the San Diego Municipal Code is amended by amending Section 131.0231, to read as follows:

§131.0231 Development Regulations Table for Open Space Zones

The following development regulations apply in the open space zones as shown in Table 131-02C.

**Table 131-02C
Development Regulations of Open Space Zones**

Development Regulations [See Section 131.0230 for Development Regulations of Open Space Zones]	Zone Designator	Zones					
	1st & 2nd >>	OP-		OC-	OR-		OF ⁽¹⁾
	3rd >>	1-	2-	1-	1-	1-	1-
	4th >>	1		1	1	2	1
Max Permitted Residential Density (DU Per Lot) [No change.]							
Min Lot Area (ac) [No change.]							
Allowable Development Area (%) [No change.]							
Min Lot Dimensions [No change.]							
Setback Requirements							
Min Front Setback (ft)		--	--	15 ⁽⁶⁾	25	--	
Min Side Setback (ft)		--	--	8 ⁽⁷⁾	20	--	
Min Street Side Setback		--	--	10 ⁽⁷⁾	20	--	
Min Rear Setback (ft)		--	--	20 ⁽⁸⁾	25	--	
Max Structure Height (ft) [[No change.]				30	30		
Max Lot Coverage (%)		--	--	--	10	--	
Max Floor Area Ratio		--	--	0.45	0.10	--	

Footnotes for Table 131-02C

1-5 [No change.]

6 See Section 131.0260(a).

7 See Section 131.0260(b).

8 See Section 131.0260(c).

Section 38. That Chapter 13, Article 1, Division 2, of the San Diego Municipal Code is amended by adding Section 131.0260, to read as follows:

§131.0260 Setback Requirements in the OR-1-1 Zone

Setbacks in the OR-1-1 Zone.

(a) *Front Setback*

- (1) For that portion of a lot that fronts a *cul-de-sac*, the minimum front setback may be reduced to 10 feet.

- (2) For *lots* where at least one-half of the front 50 feet of the *lot* depth has a minimum slope gradient of 25 percent, the *setback* closest to the *street frontage* may be reduced to a minimum of 6 feet.

(b) Side and *Street Side Setbacks*

- (1) For *lots* exceeding 50 feet in width, each side *setback* shall be at least 8 feet or 10 percent of the width of the *lot*, whichever is greater, except one side *setback* may observe 8 feet as long as the combined dimensions of both side *setbacks* equals at least 20 percent of the *lot* width.
- (2) For *lots* with 40 to 50 feet in width, each side *setback* is a minimum of 4 feet.
- (3) For *lots* with less than 40 feet in width, each side *setback* may be reduced to 10 percent of the *lot* width but shall not be reduced to less than 3 feet.
- (4) The *street side setback* is at least 10 feet or 10 percent of the *lot* width, whichever is greater.
- (5) For irregularly shaped *lots*, such as pie shaped *lots*, the *setbacks* are based on the average *lot* width for the first 50 feet of *lot* depth.
- (6) For consolidated *lots*, the width for determining *setback* requirements is the width of the *premises* after the consolidation.

(c) Rear *Setback*

The required rear *setback* is at least 20 feet, except as follows:

- (1) For *lots* with less than 100 feet in depth, the rear *setback* is at least 10 percent of the *lot* depth, but not less than 5 feet; and

- (2) For *lots* with greater than 200 in depth, the rear *setback* is at least 10 percent of the *lot* depth.

Section 39. That Chapter 13, Article 1, Division 4, of the San Diego Municipal Code is amended by amending Section 131.0443, to read as follows:

§131.0443 Setback Requirements in Residential Zones

(a) *Setbacks* in RE and RS Zones

(1) and (2) [No change.]

(3) Side and *Street Side Setbacks* in all RE Zones and the RS-1-1, RS-1-2, RS-1-3, RS-1-4, RS-1-5, RS-1-6, RS-1-7 Zones,

(A) For *lots* exceeding 50 feet in width, each side *setback* shall be at least the dimension shown in Tables 131-04C and 131-04D or 10 percent of the width of the *lot*, whichever is greater, except one side *setback* may observe the minimum dimension shown in Tables 131-04C and 131-04D as long as the combined dimensions of both side *setbacks* equals at least 20 percent of the lot width. Once a side *setback* is established, all additions to the primary *structure* thereafter shall maintain the established side *setback*.

(B) through (F) [No change.]

(4) [No change.]

Section 40. That Chapter 13, Article 1, Division 4, of the San Diego Municipal Code is amended by amending Section 131.0444, to read as follows:

§131.0444 Maximum Structure Height in Residential Zones

(a) [No change.]

- (b) In the RS-1-1, RS-1-2, RS-1-3, RS-1-4, RS-1-5, RS-1-6, and RS-1-7 zones, *structure height* shall not exceed the height of the *building envelope*. Abutting the required front, side, and street side yards, the height of the *building envelope* above 24 feet is established by the angled *building envelope* planes shown in Table 131-04H up to the maximum permitted 30-foot *structure height*, as shown in Diagram 131-04L. If the maximum *structure height* does not exceed 27 feet, the angle above 24 feet is required only at the side yards.

**Table 131-04H
Required Angle Building Envelope Plane**

Lot Width: h	Angle of Plane ¹
Less than 75 feet	45 degrees
75 feet to 150 feet	30 degrees
Greater than 150 feet	0 degrees

Diagram 131-04L

Angled Building Envelope Planes in RS, RX, and RT Zones

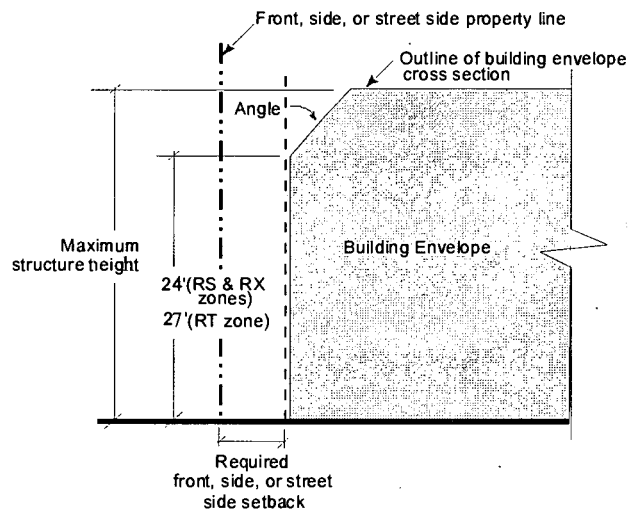

- (c) In the RS-1-1, RS-1-2, RS-1-3, RS-1-4, RS-1-5, RS-1-6, RS-1-7, RM-1-1, RM-1-2, RM-1-3 and RX zones chimneys and *dormers* may project into the space above the angled *building envelope* planes to a maximum *structure*

height of 30 feet. *Dormers* encroaching into the space above the angled *building envelope* are subject to the provisions in Sections 131.0461(a)(9) and 131.0461(b)(6) (Architectural Projections and Encroachments).

- (d) In the RX zones, the *structure height* shall not exceed the height of the *building envelope*. Abutting the required front, side, and street side yards, the height of the *building envelope* above 24 feet is established by a 45-degree angled *building envelope* plane up to the maximum permitted 30-foot *structure height*. If the maximum *structure height* does not exceed 27 feet in height, the 45-degree angled *building envelope* plane is required only along the side yards. The angled *building envelope* planes shall be measured in accordance with Diagram 131-04L.
- (e) In the RT zone, for buildings with a slab foundation, the maximum permitted *structure height* is 21 feet for one- and two-story *structures* or 31 feet for three-story *structures*. For buildings with a conventional raised *floor*, the maximum permitted *structure height* is 25 feet for one- and two-story *structures* or 35 feet for three-story *structures*. For buildings with sloped roofs with at least a 3:12 pitch (3 vertical feet to 12 horizontal feet), the maximum permitted *structure height* is increased by 5 feet. In all cases, unless otherwise excepted, the height of the *building envelope* above 27 feet adjacent to the front *setback line* is established by a 30-degree angled *building envelope* plane slanting inward to the maximum permitted *structure height*. The angled *building envelope* planes shall be measured in accordance with Diagram 131-04L.
- (f) *Structure Height* Requirements in RM-1-1, RM-1-2, RM-1-3 Zones
 - (1) [No change in text.]

(A) [No change.]

Diagram 131-04M

Angled Building Envelope at Front Setback

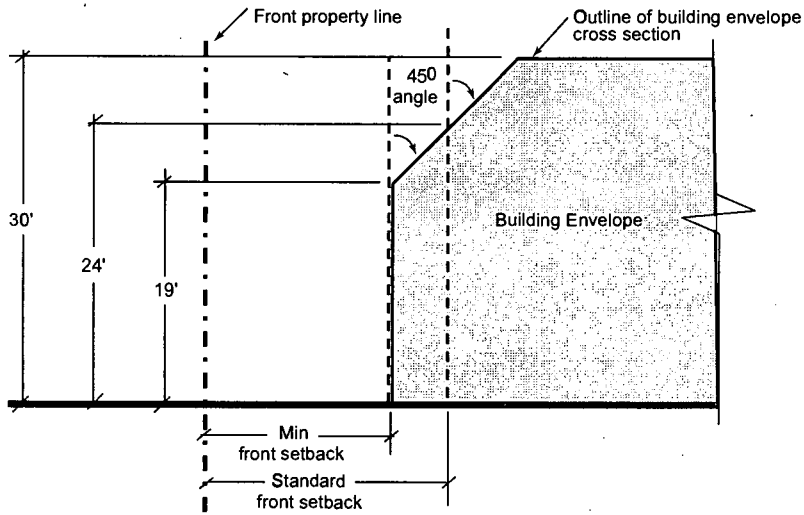

(B) The *building envelope* may have a projection outside the angled *building envelope* area for up to 33 percent of the width of the *building envelope* facing the front yard. The maximum depth of the projection shall be equal to or less than its width.

See Diagram 131-04N.

Diagram 131-04N

Exception for Angled Building Envelope Area

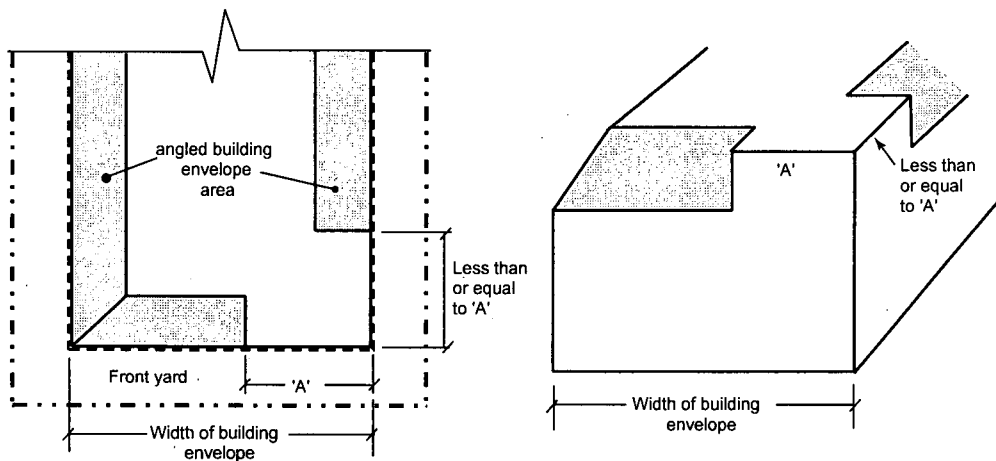

9

STREET

NOTE: 'A' shall not exceed 33% of the width of the building envelope

(C) At the side *setback line*, the height of the *building envelope* above 24 feet in height is established by a 45-degree *building envelope* plane sloping inward to the maximum permitted 30-foot *structure height*.

(2) *Dormers* may project into the space above the 45-degree angled *building envelope* planes, as shown in Diagram 131-04O, subject to the following:

- (A) A *dormer* may not extend beyond a height of 30 feet;
- (B) The aggregate width of a *dormer* may not exceed 30 percent of the length of the roof plan to which the *dormers* will be attached;
- (C) Each *dormer* may not exceed 8 feet in width measured at the widest point; and
- (D) There shall be at least 4 feet between each *dormer*.

Diagram 131-040

Dormer Projection Beyond Angled Building Envelope Plane

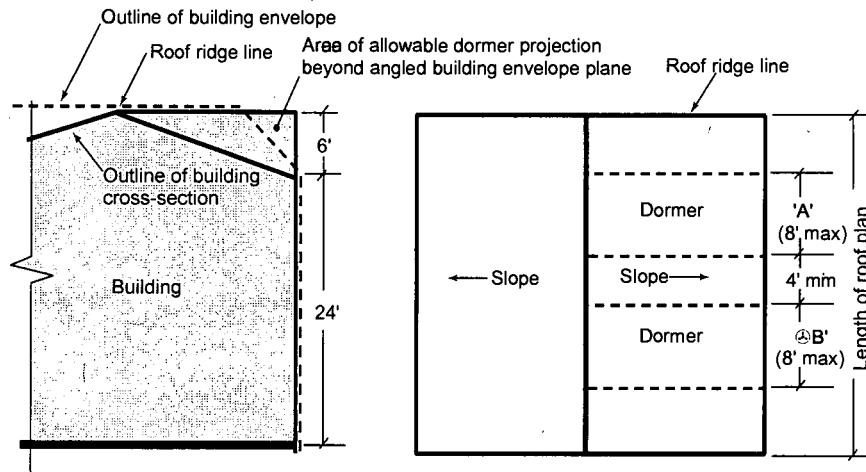

NOTE: Total width of dormer projections ('A' + 'B') shall not exceed 30% of length of roof plan in RM -1-1, RM -1-2, RM -1-3 zones or 50% of length of roof plan in RM -2-4, RM -2-5, RM -2-6 zones.

Section

Roof Plan

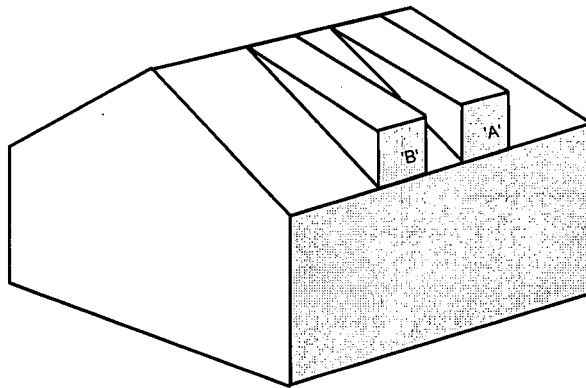

3-Dimension

(g) Structure Height Requirements in RM-2-4, RM-2-5, RM-2-6 Zones

(1) [No change.]

(2) *Dormer* may project into the space above the 60-degree angled *building envelope* planes, as shown in Diagram 131-040 subject to the following:

(A) The aggregate width of *dormers* may not exceed 50 percent of the length of the roof plan to which the *dormers* will be attached; and

- (B) *Dormers* may not extend beyond a height of 40 feet.

Section 41. That Chapter 13, Article 1, Division 4, of the San Diego Municipal Code is amended by amending Section 131.0461, to read as follows:

§131.0461 Architectural Projections and Encroachments in Residential Zones

- (a) [No change in text of first paragraph.]
 - (1) and (2) [No change.]
 - (3) Bay windows may project into required *yards*, as shown in Diagram 131-04V, subject to the following requirements:
 - (A) [No change.]
 - (B) The bay window shall not project into the required *yard* more than 4 feet or 50 percent of the width of the required *yard*, whichever is less. The bay window shall not be closer than 3 feet to the *property line*;
 - (4) through (7) [No change.]
- (b) [No change.]
 - (1) and (2) [No change.]
 - (3) Turrets with or without cupola may encroach into the required minimum front and street side *yards* and may extend into the sloped *building envelope* area subject to the following requirements:
 - (A) through (C) [No change.]
 - (D) A turret (and cupola) may also extend above the building height limit and into the sloped *building envelope* area so that the highest point is up to 5 feet above the maximum *structure height* of the base zone. However, no *structure* or addition to a *structure* shall be permitted to exceed the established height

limit of any overlay zone. (See Overlay Zones Chapter 13, Article 2, Division 1.)

(4) and (5) [No change.]

(6) *Dormers* may project into required minimum front and street side yards subject to the following requirements:

(A) through (C) [No change.]

(7) [No change.]

(c) [No change.]

Section 42. That Chapter 13, Article 1, Division 4, of the San Diego Municipal Code is amended by amending Section 131.0464, to read as follows:

§131.0464 Supplemental Requirements for Residential Zones

(a) and (b) [No change.]

(c) Supplemental Requirements for RT Zones:

(1) and (2) [No change.]

(3) One building articulation feature from each category listed below shall be incorporated into each dwelling unit:

Category A and Category B [No change.]

Category C

Planter boxes

Trellises

Inset windows

Projecting covered entry

Dormers Inset entry

(A) through (K) [No change.]

(L) *Dormers.* *Dormers* may project into the space above the angled *building envelope* plane. *Dormers* may have pitched or curved roofs. The maximum width for *dormers* is 5 feet. At the side

and *street side setbacks* a minimum separation of 10 feet between *dormers* is required. (See Section 131.0461(b)(6) for *yard encroachment* regulations).

(M) [No change.]

(d) through (f) [No change.]

Section 43. That Chapter 13, Article 1, Division 4, of the San Diego Municipal Code is amended by adding Section 131.0466, to read as follows:

§131.0466 Deviations from Development Regulations for Reasonable Accommodations

The Federal Fair Housing Act and the California Fair Employment and Housing Act require that jurisdictions make *reasonable accommodations* to afford *disabled persons* the equal opportunity to use and enjoy a dwelling. In consideration of the special need and the potential benefit that can be accomplished with a requested modification, deviations may be approved through Process One or Process Two as described below.

(a) Deviations from the following regulations may be permitted through a Process

One building permit:

- (1) Minimum *setback* requirements;
- (2) Minimum parking requirements; and
- (3) Minimum *floor area ratio* requirements for deviations less than or equal to 5 percent.

(b) Deviations from the following regulations may be permitted with a Neighborhood Development Permit decided in accordance with Process Two:

- (1) Minimum *floor area ratio* requirements for deviations greater than 5 percent, but no greater than 10 percent;

- (2) Angled *building envelope* plane requirements, not to exceed a maximum *structure height* of 30 feet;
 - (3) Accessory *structure* requirements.
- (c) Deviations from the *development* regulations described in Section 131.0466(a) may be approved subject to the following:
- (1) The development will be used by a *disabled* person;
 - (2) The deviation request is the minimum necessary to make specific housing available to a *disabled person* and complies with all applicable development regulations to the maximum extent feasible;
 - (3) The deviation request will not impose an undue financial or administrative burden on the City;
 - (4) The deviation request will not create a fundamental alteration in the implementation of the City's zoning regulations.
- (d) Deviations from the *development* regulations described in Section 131.0466(b) may be approved subject to the following:
- (1) The development will be used by a *disabled* person;
 - (2) The deviation request is the minimum necessary to make specific housing available to a *disabled person* and complies with all applicable development regulations to the maximum extent feasible;
 - (3) The deviation request will not impose an undue financial or administrative burden on the City;
 - (4) The deviation request will not create a fundamental alteration in the implementation of the City's zoning regulations;
 - (5) The deviation request will not adversely affect surrounding uses.

Section 44. That Chapter 13, Article 1, Division 5, of the San Diego Municipal Code is amended by amending Section 131.0540, to read as follows:

§131.0540 Maximum Permitted Residential Density and Other Residential Regulations

The following regulations apply to all residential *development* within commercial zones:

- (a) and (b) [No change.]
- (c) **Ground Floor Restriction.** Residential use and residential parking are prohibited on the ground *floor* in the front half of the *lot*, except in the CC-3-4, CC-3-5, CC-4-4, CC-4-5, CC-5-4, CC-5-5, and CV-1-2 zones, where these uses are prohibited on the ground *floor* in the front 30 feet of the *lot* as shown in Diagram 131-05A. Within the Coastal Overlay Zone, required parking cannot occupy more than 50 percent of the ground floor in the CV-1-1 or CV-1-2 zones.
- (d) [No change.]

Section 45. That Chapter 13, Article 2, Division 1, of the San Diego Municipal Code is amended by amending Section 132.1202, to read as follows:

§132.1202 Where the Mission Trails Design District Applies

- (a) and (b) [No change.]

**Table 132-12A
Mission Trails Design District Applicability**

Type of <i>Development</i> Proposal	Supplemental Development Regulations	Required Permit Type/ Decision Process
(1) Interior or exterior repairs or modifications	Exempt from this division	No permit required by this division
(2) Any <i>development</i> of new structures, expansion of existing structures, or grading on property zoned RS, RX, or RT within the Navajo or Tierrasanta communities as shown on Map No. C-916	Exempt from this division	No permit required by this division
(3) [No change.]		

Section 46. That Chapter 14, Article 1, Division 10, of the San Diego Municipal Code is amended by amending Section 141.1004, to read as follows:

§141.1004 Mining and Extractive Industries

[No change in text of first paragraph.]

(a) through (m) [No change.]

(n) In the OR-1-2 zone, the following regulations apply.

(1) Processing and other related mining activities (such as asphaltic processing) are permitted only within the allowable 25 percent development area.

(2) through (5) [No change.]

(o) [No change.]

Section 47. That Chapter 14, Article 2, Division 1, of the San Diego Municipal Code is amended by adding Section 142.0150, to read as follows:

§142.0150 Site Restoration

Restoration of *grading* undertaken without a permit is required and shall occur prior to any further development on the site. Restoration requires:

- (a) Submittal to and acceptance by the Permit Issuing Authority of a restoration plan which may include necessary monitoring by the City or a City designated party, both at the cost of the violator;
- (b) Obtaining a grading permit and receiving inspection approval from the Permit Issuing Authority; and
- (c) Compliance with any other reasonable requirements of the Permit.

Section 48. That Chapter 14, Article 2, Division 3, of the San Diego Municipal Code is amended by amending Section 142.0340, to read as follows:

§142.0340 Retaining Wall Regulations in All Zones

0-19332
DEBI

(a) through (c) [No change.]

(d) *Retaining Wall Height in Required Side Yards and Required Rear Yards*

(1) and (2) [No change.]

Diagram 142-03H

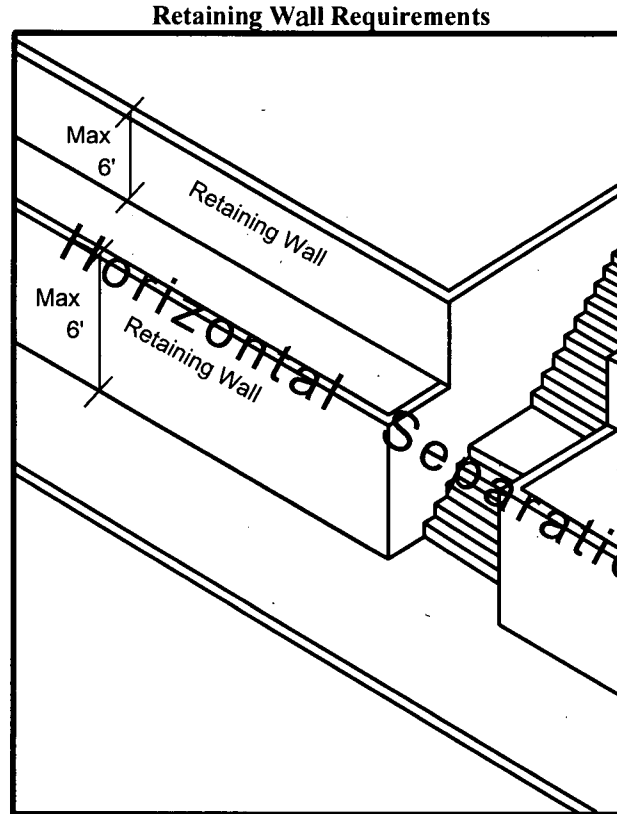

Horizontal separation distance shall be greater than or equal to the height of the upper wall

(e) through (f) [No change.]

Section 49. That Chapter 14, Article 2, Division 4, of the San Diego Municipal Code is amended by amending Section 142.0402, to read as follows:

§142.0402 When Landscape Regulations Apply

(a) [No change.]

(b) Table 142-04A provides the applicable regulations and type of permit required by this division for the landscaping required in conjunction with the

specific types of *development* proposals. Any project that proposes more than one of the types of *development* shown is subject to all of the regulations for each type of *development*.

Table 142-04A

Landscape Regulations Applicability

Type of Development Proposal			Applicable Regulations	Required Permit Type/ Decision Process
Column A	Column B	Column C		
1. – 10. [No change.]				
11.	New trees or shrubs planted in the <i>public right-of-way</i>		62.0603, 129.0702, 142.0403 and 142.0409	<i>Public Right-Of-Way Permit or Street Tree Permit/ Process One</i>

Section 50. That Chapter 14, Article 2, Division 5, of the San Diego Municipal Code is amended by amending Section 142.0560, to read as follows:

§142.0560 Development and Design Regulations for Parking Facilities

(a) through (b) [No change.]

(c) [No change in text.]

Table 142-05K [No change.]

Diagram 142-05B

Minimum Dimensions for Automobile Parking Spaces and Aisles

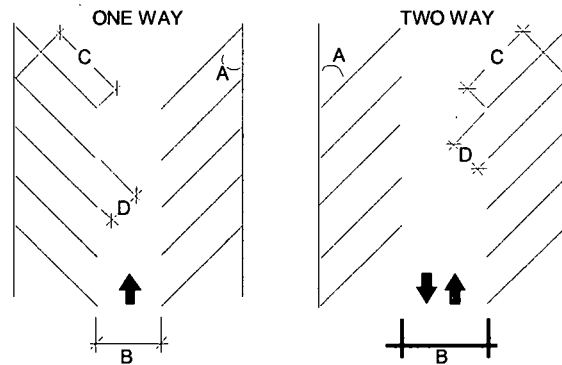

- A. Angle between parking space and aisle
- B. Aisle width
- C. Space length: 18'
- D. Space width: 8'3" retail sales and restaurant uses.
(all other uses 8')

(1) and (2) [No change.]

(d) through (k) [No change.]

Section 51. That Chapter 14, Article 2, Division 6, of the San Diego Municipal Code is amended by adding Section 142.0607, to read as follows:

§142.0607 Repair and Replacement of Public Facilities

Where in the course of *development* of private property, public facilities are damaged or removed the property owner shall, at no cost to the City, repair or replace the public facility to the satisfaction of the City Engineer.

Section 52. That Chapter 14, Article 2, Division 6, of the San Diego Municipal Code is amended by amending Section 142.0611, to read as follows:

§142.0611 Exemptions from Requirement to Provide Public Improvements Incidental to a Building Permit

The following activities are exempt from Section 142.0610:

(a) through (d) [No change.]

(e) The alteration of an existing *single dwelling unit*.

Section 53. That Chapter 14, Article 2, Division 6, of the San Diego Municipal Code is amended by amending Section 142.0670, to read as follows:

§142.0670 Standards for Public Improvements

(a) Streetscape and *street* improvements shall be constructed in accordance with the applicable adopted Council Policies, the standards established in the Land Development Manual, and the following regulations:

(1) For urbanized communities as designated in the Progress Guide and General Plan, the design of sidewalks shall be in *substantial conformance* with the historic design of sidewalks on adjacent properties including location, width, elevation, scoring pattern, texture, color, and material to the extent that the design is approved by the City Engineer, unless an alternative design is approved as part of a use permit or *development permit*. An alternative design also requires an *Encroachment* Maintenance and Removal Agreement in accordance with Section 129.0715.

(2) [No change.]

(3) All private improvements in the public right-of-way shall comply with the provisions for *encroachments* in Chapter 12, Article 9, Division 7, adopted Council Policies, and the standards established in the Land Development Manual.

(4) Public *street* improvements shall comply with the applicable regulations in the Land Development Code, adopted Council Policies, and the standards established in the Land Development Manual.

Where, in the course of *development* of private property, a driveway is abandoned and is no longer suited for vehicular use, the property

owner shall remove the depressed curb section and apron and restore the *public right-of-way* to the satisfaction of the City Engineer.

(5) and (6) [No change.]

- (b) Sewer and wastewater facilities shall be constructed in accordance with the requirements in Municipal Code Chapter 6, Article 4 (Sewers), adopted Council Policies, and the standards established in the Land Development Manual.
- (c) Water distribution and storage facilities shall be constructed in accordance with the requirements in Municipal Code Chapter 6, Article 7 (Water System), adopted Council Policies, and the standards established in the Land Development Manual.
- (d) Drainage facilities shall be constructed in accordance with the requirements in Chapter 14, Article 2, Division 2 (Drainage Regulations), adopted Council Policies, and the standards established in the Land Development Manual.
- (e) *Street* lights shall be constructed in accordance with adopted Council Policies, and the standards established in the Land Development Manual.
- (f) Traffic studies prepared by or required by the City of San Diego shall use the procedures and traffic generation rates established in the Land Development Manual.

Section 54. That Chapter 14, Article 2, Division 7, of the San Diego Municipal Code is amended by amending Section 142.0740, to read as follows:

§142.0740 Outdoor Lighting Regulations

(a) and (b) [No change.]

(c) Outdoor lighting fixtures that are existing and were legally installed before October 28, 1985, shall be exempt from Sections 142.0740(a) and 142.0740(b), unless work is proposed over any period of time to replace 50 percent or more of the existing outdoor light fixtures or to increase the number of outdoor light fixtures by 50 percent or more on the *premises*.

(d) and (e) [No change.]

Section 55. That Chapter 14, Article 2, Division 8, of the San Diego Municipal Code is amended by amending Section 142.0810, to read as follows:

§142.0810 General Regulations for Refuse and Recyclable Material Storage

[No change in the first paragraph].

(a) [No change.]

(b) Location of Material Storage Areas

(1) through (5) [No change.]

(6) For commercial *development on premises* not served by an *alley*, material storage areas shall be located at least 25 feet from any pedestrian and vehicular access points.

(c) [No change.]

Section 56. That Chapter 14, Article 2, Division 1, of the San Diego Municipal Code is amended by amending Section 142.1240, to read as follows:

§142.1240 Ground Signs in Commercial and Industrial Zones

[No change in text of first sentence.]

(a) and (b) [No change.]

(c) Table 142-12H provides the general regulations for *ground signs*.

**Table 142-12H
Maximum Allowances for Ground Signs**

Maximum Allowances	Sign Categories		
	A	B	C

Maximum Allowances	Sign Categories		
	A	B	C
Permitted Sign Area [No change.]			
Number of Signs per Street Frontage [No change.]			
Maximum Height ⁽⁵⁾	30 ft	15 ft	8 ft
Freeway-oriented ⁽³⁾ [No change.]			
Premises located within 100 feet of residentially zoned property ⁽⁴⁾ [No change.]			
Visibility areas (see Section 113.0273)	3 ft	3 ft	3 ft
Required Setbacks [No change.]			

(d) [No change.]

(e) Locational Regulations for *Ground Signs*

(1) [No change.]

(2) [No change in text of first sentence.]

(A) [No change.]

(B) The entire *premises* is within 100 feet of the boundary of the residentially zone property, and the *sign* is located on the 25 percent of the *premises* that is farthest from that property. The *sign* shall not exceed the maximum height permitted in Table 142-12H.

(3) and (4) [No change.]

(f) and (g) [No change.]

Section 57. That Chapter 14, Article 3, Division 1, of the San Diego Municipal Code is amended by amending Section 143.0110, to read as follows:

§143.0110 When Environmentally Sensitive Lands Regulations Apply

[No change in text of first sentence.]

(a) and (b) [No change.]

(c) A Neighborhood Development Permit or Site Development Permit is not required for the following *development* activity:

(1) through (7) [No change.]

(8) Site reconnaissance and testing for proposed projects, provided that:

(A) Any direct or indirect effects on *sensitive biological resources* are addressed in accordance with the Biology Guidelines of the Land Development Manual.

(B) Any subsurface explorations for *historical resources* are conducted in conformance with the Historical Resources Guidelines of the Land Development Manual.

(C) A bond consistent with Section 129.0119 has been submitted for revegetation of disturbed areas.

Section 58. That Chapter 14, Article 3, Division 1, of the San Diego Municipal Code is amended by amending Section 143.0111, to read as follows:

§143.0111 Limited Exceptions from Environmentally Sensitive Lands Regulations

No change to the first paragraph.

(a) through (h) [No change.]

(i) Public linear trail and public maintenance access projects are exempt from the development area regulations of the OR-1-2 zone in Section 131.0250(b) and the development area regulations for *steep hillsides* in Section 143.0142(a) and for *sensitive biological resources* in Section 143.0141(d).

Section 59. That Chapter 14, Article 3, Division 1, of the San Diego Municipal Code is amended by amending Section 143.0126, to read as follows:

§143.0126 Emergency Authorization to Impact Environmentally Sensitive Lands

Whenever *development* activity within *environmentally sensitive lands* is deemed necessary by order of the City Manager to protect the public health or safety, the City Manager may authorize, without a public hearing, the minimum amount of impact necessary to protect the public health or safety, subject to the following:

- (a) If the emergency work involves only temporary impacts to *environmentally sensitive lands*, a Neighborhood Development Permit or Site Development Permit is not required provided the *environmentally sensitive lands* are restored, in a timely manner to their natural state, to the satisfaction of the City Manager. Restoration shall be in accordance with a restoration plan that conforms with the Biology Guidelines and is approved by the City Manager. The restoration plan shall be submitted to the City Manager within 60 days of completion of the emergency work and work on the approved restoration plan shall be initiated within 90 days of project completion or prior to the beginning of the next rainy season, whichever is greater.

(b) and (c) [No change.]

Section 60. That Chapter 14, Article 3, Division 1, of the San Diego Municipal Code is amended by amending Section 143.0140, to read as follows:

§143.0140 General Development Regulations for all Environmentally Sensitive Lands

[No change in text of first sentence.]

- (a) *Environmentally sensitive lands* that are outside of the allowable development area on a *premises* shall be left in a natural state and used only for those passive activities allowed as a condition of permit approval. The landowner may elect to offer to dedicate in fee the undeveloped remainder portion of the *premises* to the City to relieve the land owner of management and liability obligations associated with that portion of the *premises*. Otherwise, the

passive activities allowed on the undeveloped remainder of the *premises* and any other conditions of the permit shall be incorporated into a covenant of easement that shall be recorded against title to the property, in accordance with procedures set forth in Section 143.0152.

(b) through (d) [No change.]

Section 61. That Chapter 14, Article 3, Division 1, of the San Diego Municipal Code is amended by amending Section 143.0142, to read as follows:

§143.0142 Development Regulations for Steep Hillsides

[No change in text of first sentence.]

(a) Allowable Development Area

(1) through (3) [No change.]

(4) [No change in text of first paragraph.]

(A) When *encroachment* onto such *steep hillsides* is unavoidable, *encroachment* shall be minimized; except that *encroachment* is permitted in such *steep hillsides* to provide for a development area of up to a maximum of 25 percent of the *premises* on *premises* containing less than 91 percent of such *steep hillsides*. On *premises* containing 91 percent or greater of such *steep hillsides*, the maximum allowable development area is 20 percent of the *premises*; however, an additional 5 percent *encroachment* into such *steep hillsides* may be permitted if necessary to allow an economically viable use, pursuant to the Steep Hillside Guidelines.

(B) [No change.]

- (C) Up to an additional 15 percent of *encroachment* onto such *steep hillsides* is permitted for the following:
- (i) and (ii) [No change.]
 - (iii) In the North City Local Coastal Program Land Use Plan areas only: Local public streets or private roads and driveways which are necessary for access to the more developable portions of a site containing slopes of less than 25 percent grade, provided no less environmentally damaging alternative exists. The determination of whether or not a proposed road or driveway qualifies for an exemption, in whole or in part, shall be made by the City Manager based upon an analysis of the project site.
- (D) For the purposes of Section 143.0142, *encroachment* shall be defined as any area of 25 percent or greater slope in which the natural landform is altered by grading, is rendered incapable of supporting vegetation due to the displacement required for the building, accessory structures, or paving, or is cleared of vegetation (including Zone 1 brush management).
- (E) In the approval of any Coastal Development Permit for a *subdivision*, and any other division of land, including lot splits, no *encroachment* into *steep hillsides* containing *sensitive biological resources*, or mapped as Viewshed or Geologic Hazard on Map C-720 shall be permitted, and the decision maker shall require a minimum 30 foot setback for Zone 1

brush management for *coastal development* from such *steep hillsides*.

(b) through (h) [No change.]

Section 62. That Chapter 14, Article 3, Division 1, of the San Diego Municipal Code is amended by amending Section 143.0144, to read as follows:

§143.0144 Development Regulations for Coastal Beaches

[No change in the first paragraph.]

(a) [No change.]

(b) All *development* occurring on a site containing *coastal beaches* must conform with the Coastal Bluffs and Beaches Guidelines in the Land Development Manual.

(c) through (j) [No change.]

Section 63. That Chapter 14, Article 3, Division 3, of the San Diego Municipal Code is amended by amending Section 143.0302, to read as follows:

§143.0302 When Supplemental Neighborhood Development Permit and Site Development Permit Regulations Apply

[No change in text of first sentence.]

**Table 143-03A
Supplemental Neighborhood Development Permit or Site Development Permit
Regulations Applicability**

Type of Development Proposal	Applicable Sections	Required Development Permit/Decision Process
Affordable/In-Fill Housing Projects with Deviations	[No change.]	[No change.]
Site Containing <i>Environmentally Sensitive Lands</i>	[No change.]	[No change.]
Site Containing <i>Historical Resources</i>	143.0201, 143.0260, 143.0303, 143.0305, 143.0360, 143.0375, 143.0380	NDP/Process Two or SDP/Process Four
<i>Fences or Retaining Walls Exceeding the Permitted Height</i>	[No change.]	[No change.]
Relocated Building Onto a Site With an Existing Building	[No change.]	[No change.]

019332

Type of Development Proposal	Applicable Sections	Required Development Permit/Decision Process
Site with <i>Previously Conforming Conditions</i>	127.0102-127.0106, 143.0303, 143.0305, 143.0375	NDP/Process Two
Nonresidential <i>Development Exceeding the Maximum Permitted Parking</i>	[No change.]	[No change.]
Shared Parking for Uses Not Listed in Section 142.0545(c)	[No change.]	[No change.]
Commercial <i>Development With Tandem Parking</i>	[No change.]	[No change.]
<i>Previously Conforming Parking</i> for a discontinued use	[No change.]	[No change.]
<i>Mobilehome Parks</i> in RM Zones	[No change.]	[No change.]
<i>Mobilehome Parks</i> in RS, RX Zones	[No change.]	[No change.]
Discontinuance of <i>Mobilehome Park</i>	143.0610-143.0640 , 132.0701-132.0705 , 143.0303, 143.0305, 143.0375	SDP/Process Three
Multiple Dwelling Unit <i>Development</i> that Varies from Minimum Parking Requirements	[No change.]	[No change.]
Nonresidential <i>Development (With TDM Plan)</i> that Varies from Minimum Parking Requirements	[No change.]	[No change.]
Community Plan Implementation Overlay Zone	[No change.]	[No change.]
Mission Trails Design District	[No change.]	[No change.]
<i>Development</i> Within the Urban Village Overlay Zone	[No change.]	[No change.]
<i>Public improvements</i> on More Than 3,000 Feet of Frontage or Where City Standards Do Not Apply	[No change.]	[No change.]
Manufactured Slopes in Excess of 25% Gradient and 25 Feet in Height	[No change.]	[No change.]
Affordable Housing in RE, RS, RX, RT, AR Zones	143.0303, 143.0305, 143.0310, 143.0375,143.0380, 143.0710-143.0740	SDP/Process Three
Affordable Housing with Deviations from Development Regulations	143.0303, 143.0305, 143.0310, 143.0375,143.0380, 143.0760	SDP/Process Four
Multiple Dwelling Unit <i>Development</i> in RM Zones Involving <i>Lot Consolidation</i> and Exceeds Number of Units Indicated in Table 126-05A	143.0303, 143.0305, 143.0310, 143.0375,143.0380	SDP/Process Three
Clairemont Mesa Height Limit Overlay Zone	132.1301-132.1306 , 143.0303, 143.0305, 143.0375,143.0380	SDP/Process Five

Legend to Table 143-03A [No change.]

Section 64. That Chapter 14, Article 4, Division 2, of the San Diego Municipal Code is amended by adding Section 144.0231, to read as follows:

§144.0231 Right-of-Way Improvements and Land Development for Tentative Maps

(a) through (f) [No change.]

(g) Any private improvements existing or to be installed in public right-of-way shall require Encroachment Maintenance and Removal Agreements in accordance with Section 129.0715.

Section 65. That Chapter 14, Article 4, Division 2, of the San Diego Municipal Code is amended by adding Section 144.0233, to read as follows:

§144.0233 Acceptance of Dedication

No reservation for *public rights-of-way* shall be offered for dedication unless such offer includes any necessary slope easements required for the ultimate development of the *public right-of-way*, and no such reservation shall be accepted for dedication by the City until improvements therein are constructed pursuant to the requirements of this Code.

The City Engineer, or other designee of the City Manager, may accept on behalf of the City Council *streets* and roads, or portions thereof, into the City *street system* and record conveyances to the City of real property interests for *street* and road uses and purposes. No *street* shall be accepted into the City *street system* and open to public use until improvements are constructed pursuant to the requirements of this Code.

Section 66. That Chapter 14, Article 6, Division 1, of the San Diego Municipal Code is amended by amending Section 146.0106, to read as follows:

§146.0106 Sub-Sections of the 2001 California Electrical Code That Have Been Adopted with Modifications

Article 384, Switchboards and Panelboards, Section 3, Support and Arrangement of Busbars and Conductors, sub-Section (f)(1) Phase Arrangement is adopted with modifications as follows:

The phase arrangement on three-phase buses shall be A, B, C, from front to back, top to bottom, or left to right, as viewed from the front

of the switchboard or panelboard. The C phase shall be that phase having the higher voltage to ground on three-phase (3- phase), four-wire (4-wire) delta connected systems. Other busbar arrangements may be permitted for additions to existing installations.

Section 67. That a full reading of this ordinance is dispensed with prior to its final passage, a written or printed copy having been available to the City Council and the public a day prior to its final passage.

Section 68. That this ordinance shall take effect and be in force on the date it is effectively certified by the California Coastal Commission as a City of San Diego Local Coastal Program amendment, but not sooner than thirty days from the date of adoption by the City Council.

APPROVED: CASEY GWINN, City Attorney

By

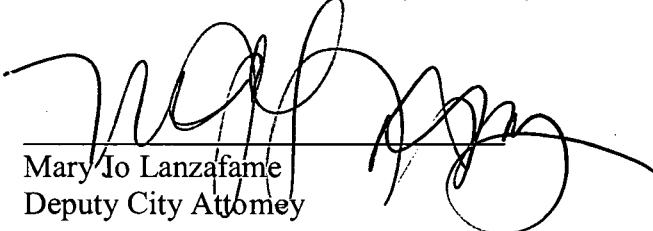
Mary Jo Lanzafame
Deputy City Attorney

MJL:cfq:cdk:pev:cfq
10/22/04
10/26/04 Cor.Copy
O-2005-39
MMS#468