

**Article 2: General Development Regulations**

**Division 3: Fence Regulations**

*(Added 12-9-1997 by O-18451 N.S.; effective 1-1-2000.)*

**§142.0301 Purpose of Fence Regulations**

The purpose of these regulations is to maintain adequate visibility on private property and in *public rights-of-way*, to maintain the openness of front and street side yards, to protect the light and air to abutting properties, and to provide adequate *screening* by regulating the height, location, and design of *fences* and *retaining walls*.

*(Added 12-9-1997 by O-18451 N.S.; effective 1-1-2000.)*

**§142.0305 When Fence Regulations Apply**

- (a) This division applies to the construction of all *fences* and *retaining walls*, whether or not a permit or other approval is required.
- (b) Table 142-03A shows the applicable regulations and the type of permit required by this Division, if any, for specific types of *fences*.

**Table 142-03A  
Fence Regulations Applicability**

<b>TYPE OF DEVELOPMENT PROPOSAL</b>	<b>APPLICABLE REGULATIONS</b>	<b>REQUIRED PERMIT TYPE/ DECISION PROCESS</b>
Any <i>fence</i> with a height less than 6 feet	Sections 129.0203, 142.0310-142.0330, 142.0360-142.0380	No permit required by this division
Any <i>fence</i> with a height of 6 feet or greater	Sections 142.0310-142.0330, 142.0360-142.0380	Building Permit/Process One
Any <i>retaining wall</i> with a height less than 3 feet	Sections 129.0203, 142.0340, 142.0370, 142.0380	No permit required by this division
Any <i>retaining wall</i> with a height of 3 feet or greater	Sections 142.0340, 142.0370, 142.0380	Building Permit/Process One
Any <i>fence</i> or <i>retaining wall</i> exceeding the height permitted in Section 142.0310, 142.0320, 142.0330, and 142.0340.	Section 142.0350	Neighborhood Development Permit/Process Two
Any <i>fence</i> or <i>retaining wall</i> located on <i>premises</i> that lies between the shoreline and the first public roadway, as designated on Map Drawing No. C-731.	Section 142.0310-142.0380	Coastal Development Permit/Process Three - Appealable

(Added 12-9-1997 by O-18451 N.S.)  
 (Amended 10-18-1999 by O-18691 N.S.; effective 1-1-2000.)  
 (Amended 5-5-2015 by O-20481 N.S.; effective 6-4-2015.)

**§142.0310 General Fence Regulations for All Zones**

(a) Location and Height of *Fences*

- (1) No portion of a *fence* shall extend beyond the *property line* of the *premises* into the *public right-of-way* without a Public Right-of-Way Permit.
- (2) Up to 30 percent of the length of a *fence* may exceed the height limits specified in this division by up to 6 inches.
- (3) *Fence* height shall be measured in accordance with Section 113.0270(b).

(b) *Fence* Height in *Visibility Areas*

*Fences* in *visibility areas* shall not exceed 3 feet in height.

(c) *Fence* Height in Required Front *Yards* and Required *Street Side Yards*

(1) *Solid Fences*

- (A) *Solid fences* located on the front or *street side property line* shall not exceed 3 feet in height except as provided in Section 142.0310(c)(1)(C).
- (B) The height of a *solid fence* located in a required *yard* may increase as the *fence* is placed farther from the front or *street side property line*. No portion of the *fence* shall exceed the height established by a line drawn beginning at a point 3 feet above *grade* at the *property line* and ending at a point 6 feet above *grade* at the *setback line*, as shown in - 142-03A.

**Diagram 142-03A**

Solid Fence--Height Limit

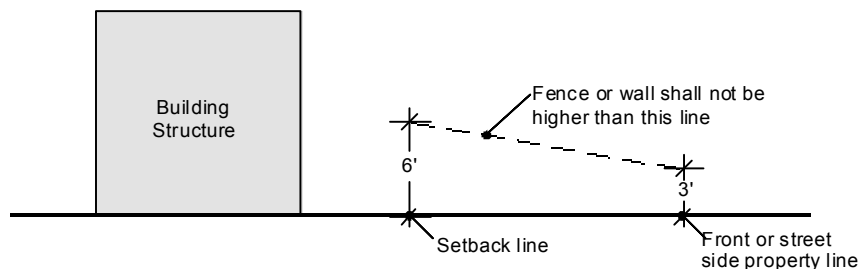

- (C) *Solid fences* located in a required *yard* that abuts a major *street*, primary arterial, or *freeway*, as identified in the applicable *land use plan*, are permitted up to 6 feet in height if there is at least one horizontal or vertical offset for every 120 square feet of *fence* area. The offset shall be at least 12 inches wide with a minimum reveal of 4 inches. See Diagram 142-03B.

**Diagram 142-03B**  
**Vertical and Horizontal Offsets**

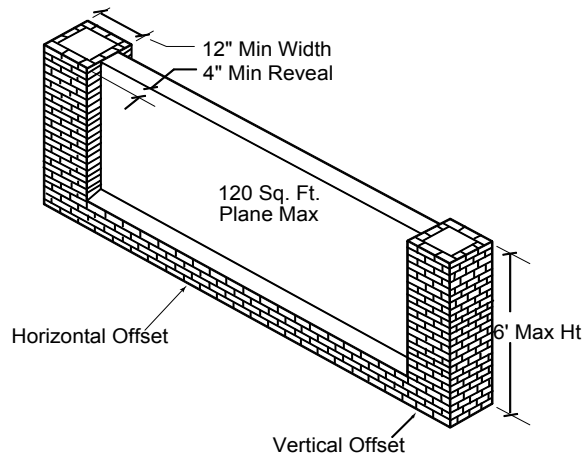

(2) *Open Fences*

- (A) Standard, all metal chain link *fences* located on the front or *street side property line* shall not exceed 3 feet in height. Other *open fences* are permitted up to 6 feet in height.
- (B) The height of an *open fence* located in a required *yard* may increase as the *fence* is placed farther from the front or *street side property line*. No portion of the *fence* shall exceed the height established by a line drawn beginning at a point 6 feet above *grade* at the *property line* and ending at a point 9 feet above *grade* at the *setback line*, as shown in Diagram 142-03C.
- (C) An *open fence* shall have at least 35 percent of the vertical surface area of each 6-foot section open to light except within the Coastal Overlay Zone, where an *open fence* shall have at least 75 percent of its vertical surface area open to light.

**Diagram 142-03C**

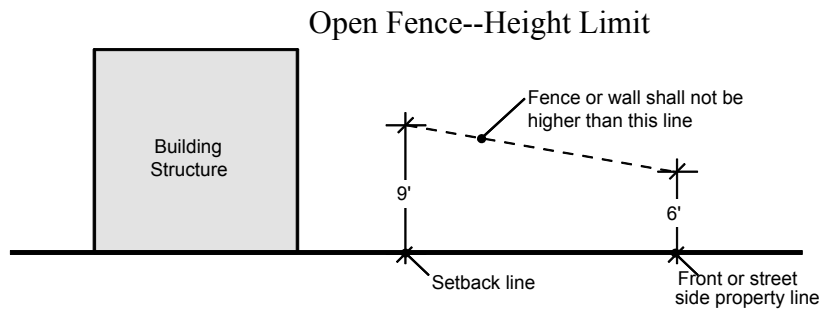

(3) *Combination (Open and Solid) Fences*

- (A) On the front or *street side property line*, an *open fence* is permitted on top of a *solid fence*, provided that the *solid fence* and any chain link *fence* do not each exceed 3 feet in height and the total height does not exceed 6 feet.
- (B) The height of a combination *fence* may increase as the *fence* is placed farther from the front or *street side property line*. No portion of the *fence* shall exceed the height established by a line drawn beginning at a point 6 feet above *grade* at the *property line* and ending at a point 9 feet above *grade* at the *setback line*, as shown in Diagram 142-03D. Where a *visibility area* is required, the beginning point shall be measured 6 feet above any point of intersection of the perimeter of the *visibility area* and the side or rear *property line*, as shown in Diagram 142-03E.

**Diagram 142-03D**

Combination Fence--Height Limit

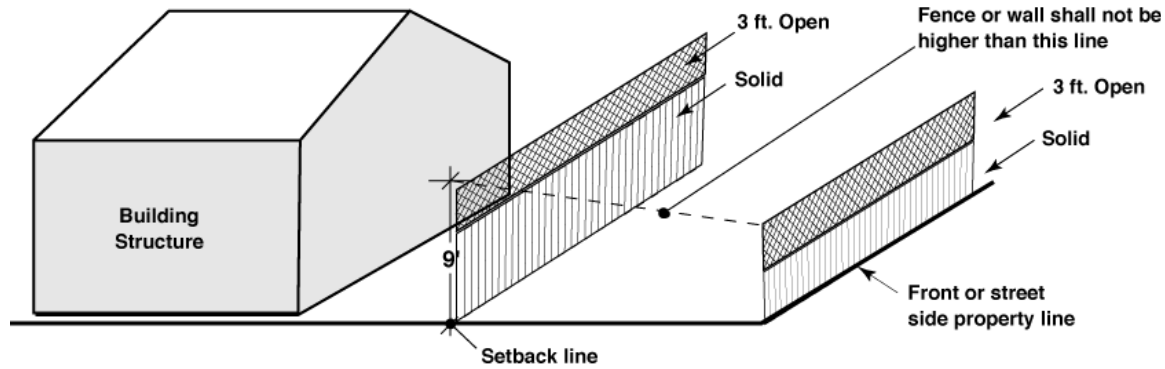

**Diagram 142-03E**

Combination Fence--Height Limit with Visibility Area

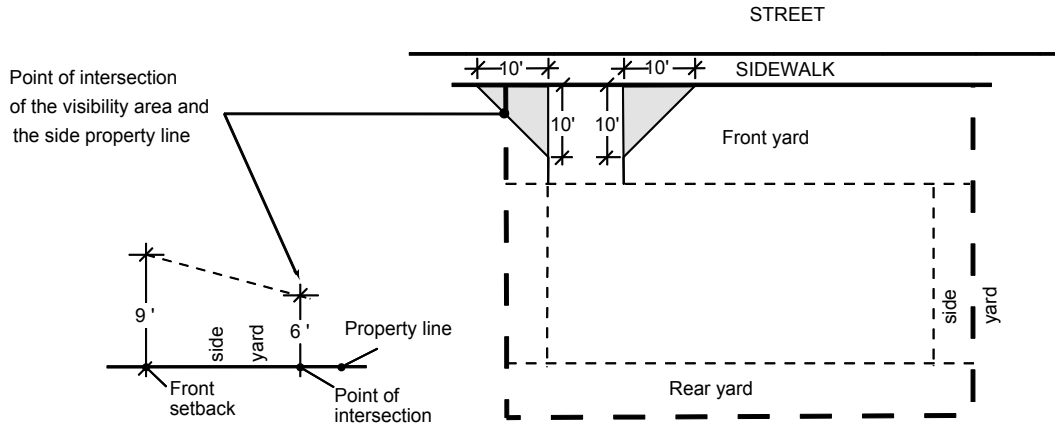

- (C) Vertical elements such as columns or posts shall be provided at least every 15 feet on a combination fence. Each vertical element shall be at least 6 inches wide (unfinished dimension), measured along the face of the fence as shown in Diagram 142-03F.
- (D) If wire fence material is used for the open portion of the fence, a horizontal element shall be provided along the top of the wire fence. This element shall be at least 1-½ inches wide with a minimum reveal of 1-½ inches, as shown in Diagram 142-03F.

Diagram 142-03F

Combination Fence--Vertical and Horizontal Elements

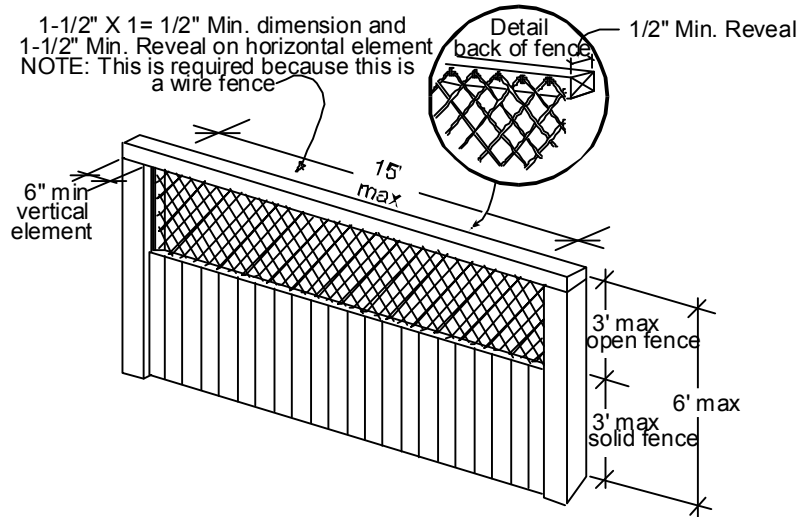

(4) *Fence Height Exception in Required Street Side Yards*

*Solid fences* located in the required *street side yard* of a *lot* with a rear *yard* that abuts the rear *yard* of another *lot*, as shown in Diagram 142-03G, are permitted up to 6 feet in height.

**Diagram 142-03G**  
**Fence in Street Side Yard**

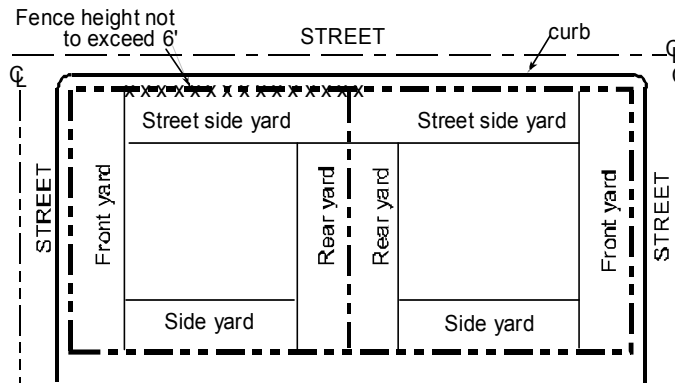

(d) *Fence Height in Required Side Yards and Required Rear Yards*

*Fences* located in required side yards and required rear yards are permitted up to 9 feet in height. Any portion of the *fence* above 6 feet in height shall be an *open fence*.

(e) *Fence Height Outside of Required Yards*

(1) *Fences* located outside of required yards, other than those listed in Section 142.0310(e)(2), shall not exceed 10 feet in height in open space, agricultural, and residential zones and 12 feet in height in commercial and industrial zones. These *fences* may be *solid fences*, *open fences*, or combination *fences*.

(2) The following *fences* are permitted outside of required yards up to the maximum *structure height* specified in the zone:

(A) *Open fences* enclosing tennis, badminton, volleyball, and other recreational and public facilities;

(B) Building, court, and wing walls or other integral portions of a building.

*(Amended 1-9-2001 by O-18910 N.S.; effective 8-8-2001.)*

*(Amended 3-1-2006 by O-19467 N.S.; effective 8-10-2006.)*

*(Amended 5-5-2015 by O-20481 N.S.; effective 6-4-2015.)*



**§142.0320 Exception to the General Fence Regulations for Residential Zones**

In the Residential Townhouse (RT) zones, *fences* located in the required rear *yard* along an *alley* adjacent to a garage are permitted up to 10 feet in height. If a *roof deck* is located on the garage, the *fence* may extend to the height of the *roof deck* railing, provided that the *fence* design is consistent with that of the railing.  
(Added 12-9-1997 by O-18451 N.S.; effective 1-1-2000.)

**§142.0330 Exceptions to the General Fence Regulations for Commercial and Industrial Zones**

(a) *Fences* in Required Rear *Yards* and Required Side *Yards*

- (1) *Solid fences* located in the required rear and side *yards* of commercially zoned property abutting a residentially zoned *lot* are permitted up to 9 feet in height.
- (2) *Solid fences* located in required rear and side *yards* of industrially zoned property are permitted up to 9 feet in height.

(b) Required *Fences*

- (1) A *solid fence* shall be constructed along all portions of commercially and industrially zoned *lots* that abut residentially zoned *lots*, unless there is a *grade* separation of more than 30 feet between the building pads of the abutting *lots*. Any gates provided in required *fences* shall also be solid. The *fence* and gate shall be 3 feet in height in required front and street side *yards* and shall be at least 6 feet but not more than 9 feet in height in required side and rear *yards*. If there is a *grade* difference of 30 feet or less between the building pads of the commercially or industrially zoned *lot* and the residentially zoned *lot*, the required 6-foot *fence* shall be located at the top of the slope between the two *lots*.
- (2) *Vehicular use areas* located in or adjacent to required front or street side *yards* shall be *screened* by a *fence* or landscaping of at least 3 feet in height. This *screen* shall be separated from the adjacent *public right-of-way* by a landscape strip that is at least 3 feet wide.

(Added 12-9-1997 by O-18451 N.S.; effective 1-1-2000.)

**§142.0340 Retaining Wall Regulations in All Zones**

(a) Location and Height of *Retaining Wall*

- (1) No portion of a *retaining wall* shall extend beyond the *property line* of the *premises* into the *public right-of-way* unless an encroachment permit has been obtained.
- (2) Up to 30 percent of the length of a *retaining wall* may exceed the height limits specified in this division by up to 6 inches.
- (3) *Retaining wall* height shall be measured in accordance with Section 113.0270(b).

(b) *Retaining Wall* Height in *Visibility Areas*

*Retaining walls* in *visibility areas* shall not exceed 3 feet in height except that a *retaining wall* may be constructed to maintain an existing cut bank adjacent to a *public right-of-way*, if the wall follows the contours of the slope.

(c) *Retaining Wall* Height in Required Front *Yards* and Required *Street Side Yards*

- (1) Two *retaining walls* with a maximum height of 3 feet each are permitted in the required front and *street side yard* if the two *retaining walls* are separated by a minimum horizontal distance equal to the height of the upper wall. See Diagram 142-03H.
- (2) An *open fence* not exceeding 3 feet, 6 inches in height is permitted on the top of the upper wall section, or an *open fence* which in combination with the upper wall section does not exceed 6 feet in height is permitted.
- (3) *Retaining walls* of 3 feet in height or greater shall have at least one horizontal or vertical offset for each 120 square feet of wall area, except where otherwise provided in Section 142.0340(f). The horizontal or vertical offset shall be at least 12 inches wide with a minimum reveal of 4 inches. See Diagram 142-03B.

(d) *Retaining Wall* Height in Required Side *Yards* and Required Rear *Yards*

- (1) Two *retaining walls* with a maximum height of 6 feet each are permitted in the required side and rear yard if the two *retaining walls* are separated by a minimum horizontal distance equal to the height of the upper wall. See Diagram 142-03H.
- (2) An *open fence* not to exceed 3 feet, 6 inches in height is permitted on top of the upper *retaining wall*.

**Diagram 142-03H**

**Retaining Wall Requirements**

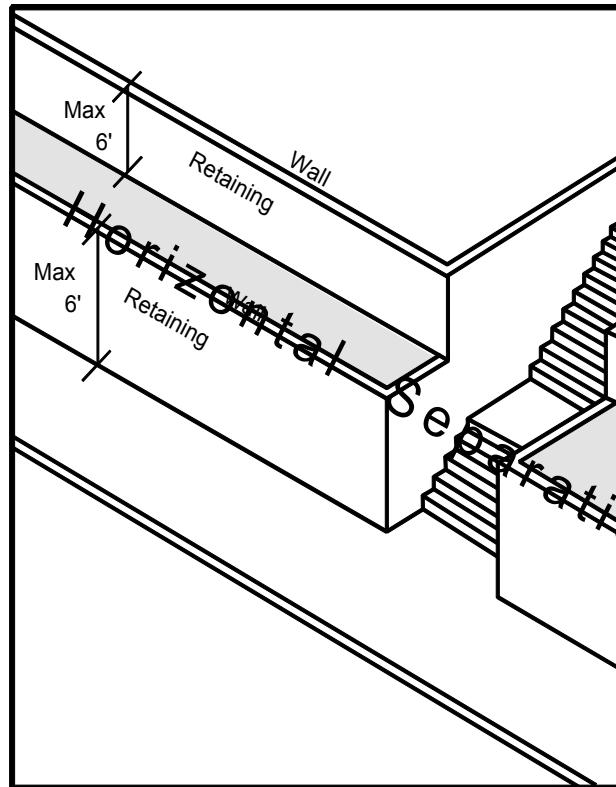

**Horizontal separation distance shall be greater than or equal to the height of the upper wall**

- (e) *Retaining Wall Height Outside of Required Yards*  
*Retaining walls* located outside of the required *yards* shall not exceed 12 feet in height.
- (f) *Exceptions to Retaining Wall Height*
  - (1) *Retaining walls* that abut a public *alley* are not required to be separated into two wall sections, and a *solid fence* up to 6 feet in height may be provided on top of the *retaining wall* if it is 6 feet high or less.

- (2) The height of a *retaining wall* and associated fencing that border an access to underground parking shall be measured from the *street grade*.
- (3) In commercial and industrial zones, a *retaining wall* not exceeding 9 feet in height is permitted in the required side and rear *yards* and shall not be required to provide a horizontal separation between walls.
- (4) When the elevation of the adjacent *street grade* is higher than the building pad, the following shall apply:
  - (A) The portion of the *retaining wall* located at or below the adjacent *street grade* is not subject to Section 142.0340(c)(3); and
  - (B) Measurement of any portion of the wall or attached *fence* above *grade* shall be taken from the adjacent *grade* on the higher side of the *retaining wall*.

*(Amended 1-9-2001 by O-18910 N.S.; effective 8-8-2001.)*  
*(Amended 11-28-2005 by O-19444 N.S.; effective 2-9-2006.)*  
*(Amended 5-5-2015 by O-20481 N.S.; effective 6-4-2015.)*

**§142.0350 Neighborhood Development Permit for Height Exception**

A Neighborhood Development Permit may be requested to permit an increase of up to 20 percent in the *fence* and *retaining wall* height limits in Sections 142.0310, 142.0320, 142.0330, and 142.0340. The decision maker may approve a Neighborhood Development Permit for a height exception only if one of the following circumstances exists:

- (a) The increase in height is justified because of variations in *grade* on the site or abutting the site;
- (b) The increase in height is justified because it conforms to the predominant height of *fences* or *retaining walls* in the neighborhood; or
- (c) The increase in height is necessary for the health and safety of persons on the property.

*(Added 12-9-1997 by O-18451 N.S.; effective 1-1-2000.)*

**§142.0360 Electrically Charged and Sharp-Pointed Fence Regulations**

- (a) Electrically Charged *Fences*
  - (1) Electrically charged *fences* are permitted in the IH and IS zones and for agricultural uses in agricultural zones if the *fence* is at least 600 feet from a residential zone, and for temporary control of goats used for brush management in any non-agricultural zones in compliance with the Land Development Code section 142.0412, Brush Management, and section 44.0307.
  - (2) Electrically charged *fences* must be approved by the Underwriter’s Laboratory or subject to the approval of the City Manager.
  - (3) Electrically charged *fences* shall bear an identifying and warning *sign* every 100 linear feet or fraction thereof.

(b) Sharp-Pointed Metal *Fences*

Sharp-pointed metal *fences* are permitted for agricultural uses in agricultural zones only.

*(Added 12-9-1997 by O-18451 N.S.; effective 1-1-2000.)*  
*(Amended 9-19-2005 by O-19413 N.S.; effective 10-19-2005.)*

**§142.0370 Construction Materials for Fences and Retaining Walls**

- (a) *Solid fences* shall be constructed of wood, brick, block, stone, frame-stucco, tile, metal, opaque plastic, or other similar material. Plywood is not a permitted *fence* material.
- (b) *Open fences* shall be constructed of materials such as wood, ornamental iron, metal, *screen* or decorative block, or translucent plastic or similar material.
- (c) Solid and *open fences* constructed of polyvinyl chloride (PVC) or similar material are permitted only if the material is prefabricated and manufactured as a *fence*.
- (d) Solid and *open fences* shall be constructed of new material or used material in good condition.
- (e) Metal *fences* in required front and street side yards shall be covered with a colored finish other than galvanized metal in all zones except the IH, IS, IL, AG and AR zones.
- (f) Natural living plant material is not considered *fence* material and is not regulated by this division.

*(Added 12-9-1997 by O-18451 N.S.; effective 1-1-2000.)*

**§142.0380 Fence and Retaining Wall Maintenance**

- (a) Property owners shall maintain *fences* and *retaining walls* free from dilapidated or dangerous conditions.
- (b) Property owners shall maintain *fences* and *retaining walls* in a graffiti-free condition.

*(Added 12-9-1997 by O-18451 N.S.; effective 1-1-2000.)*