

Article 2: General Development Regulations

Division 3: Fence Regulations

(Added 12-9-1997 by O-18451 N.S.; effective 1-1-2000.)

§142.0301 Purpose of Fence Regulations

The purpose of these regulations is to maintain adequate visibility on private property and in *public rights-of-way*, to maintain the openness of front and street side yards, to protect the light and air to abutting properties, and to provide adequate *screening* by regulating the height, location, and design of *fences* and *retaining walls*.
(Added 12-9-1997 by O-18451 N.S.; effective 1-1-2000.)

§142.0305 When Fence Regulations Apply

- (a) This division applies to the construction of all *fences* and *retaining walls*, whether or not a permit or other approval is required.
- (b) Table 142-03A shows the applicable regulations and the type of permit required by this division, if any, for specific types of *fences*.

**Table 142-03A
Fence Regulations Applicability**

TYPE OF DEVELOPMENT PROPOSAL	APPLICABLE REGULATIONS	REQUIRED PERMIT TYPE/ DECISION PROCESS
Any <i>fence</i> with a height less than 6 feet	Sections 142.0310-142.0330, 142.0360-142.0380	No permit required by this division
Any <i>fence</i> with a height of 6 feet or greater	Sections 142.0310-142.0330, 142.0360-142.0380	Building Permit/Process One
Any <i>retaining wall</i> with a height less than 3 feet	Sections 142.0340, 142.0370, 142.0380	No permit required by this division
Any <i>retaining wall</i> with a height of 3 feet or greater	Sections 142.0340, 142.0370, 142.0380	Building Permit/ Process One
Any <i>fence</i> or <i>retaining wall</i> exceeding the height permitted in Section 142.0310, 142.0320, 142.0330, and 142.0340.	Section 142.0350	Neighborhood Development Permit/Process Two
Any <i>fence</i> or <i>retaining wall</i> located on premises that lies between the shoreline and the first public roadway, as designated on Map Drawing No. C-731.	Section 142.0310-142.0380	Coastal Development Permit/Process Three - Appealable

(Added 12-9-1997 by O-18451 N.S.)
(Amended 10-18-1999 by O-18691 N.S.; effective 1-1-2000.)

§142.0310 General Fence Regulations for All Zones

(a) Location and Height of *Fences*

- (1) No portion of a *fence* shall extend beyond the *property line* of the *premises* into the *public right-of-way* unless an Public Right-of-way permit has been obtained.
- (2) Up to 30 percent of the length of a *fence* may exceed the height limits specified in this division by up to 6 inches.
- (3) *Fence* height shall be measured in accordance with Section 113.0270(b).

(b) *Fence* Height in *Visibility Areas*

Fences in *visibility areas* shall not exceed 3 feet in height.

(c) *Fence* Height in Required Front *Yards* and Required *Street Side Yards*

(1) *Solid Fences*

- (A) *Solid fences* located on the front or *street side property line* shall not exceed 3 feet in height except as provided in Section 142.0310(c)(1)(C).
- (B) The height of a *solid fence* located in a required *yard* may increase as the *fence* is placed farther from the front or *street side property line*. No portion of the *fence* shall exceed the height established by a line drawn beginning at a point 3 feet above *grade* at the *property line* and ending at a point 6 feet above *grade* at the *setback line*, as shown in - 142-03A.

Diagram 142-03A

Solid Fence--Height Limit

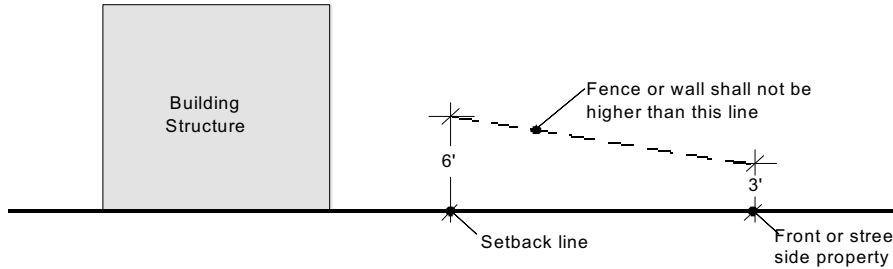

- (C) *Solid fences* located in a required *yard* that abuts a major *street*, primary arterial, or *freeway*, as identified in the applicable *land use plan*, are permitted up to 6 feet in height if there is at least one horizontal or vertical offset for every 120 square feet of *fence* area. The offset shall be at least 12 inches wide with a minimum reveal of 4 inches. See Diagram 142-03B.

Diagram 142-03B Vertical and Horizontal Offsets

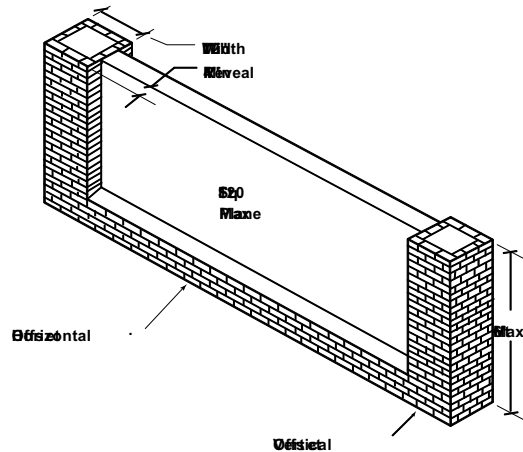

(2) *Open Fences*

- (A) Standard, all metal chain link *fences* located on the front or *street side property line* shall not exceed 3 feet in height. Other *open fences* are permitted up to 6 feet in height.
- (B) The height of an *open fence* located in a required *yard* may increase as the *fence* is placed farther from the front or *street side property line*. No portion of the *fence* shall exceed the height established by a line drawn beginning at a point 6 feet above *grade* at the *property line* and ending at a point 9 feet above *grade* at the *setback line*, as shown in Diagram 142-03C.
- (C) An *open fence* shall have at least 35 percent of the vertical surface area of each 6-foot section open to light except within the Coastal Overlay Zone, where an *open fence* shall have at least 75 percent of its vertical surface area open to light.

Diagram 142-03C

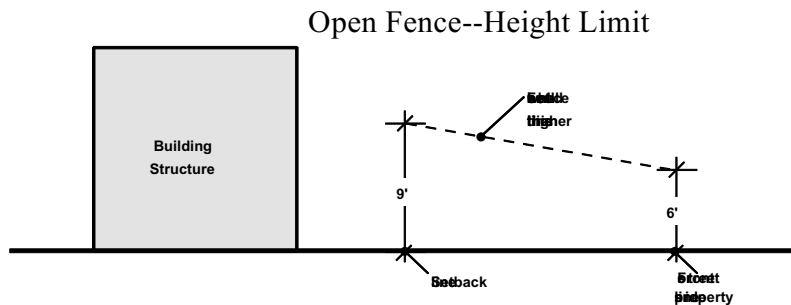

(3) *Combination (Open and Solid) Fences*

- (A) On the front or *street side property line*, an *open fence* is permitted on top of a *solid fence*, provided that the *solid fence* and any chain link *fence* do not each exceed 3 feet in height and the total height does not exceed 6 feet.
- (B) The height of a combination *fence* may increase as the *fence* is placed farther from the front or *street side property line*. No portion of the *fence* shall exceed the height established by a line drawn beginning at a point 6 feet above *grade* at the *property line* and ending at a point 9 feet above *grade* at the *setback line*, as shown in Diagram 142-03D. Where a *visibility area* is required, the beginning point shall be measured 6 feet above any point of intersection of the perimeter of the *visibility area* and the side or rear *property line*, as shown in Diagram 142-03E.

Diagram 142-03D

Combination Fence--Height Limit

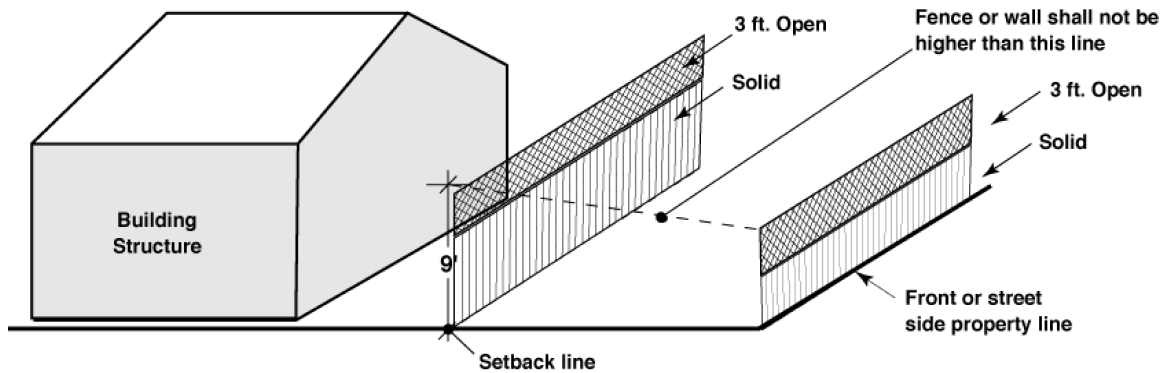
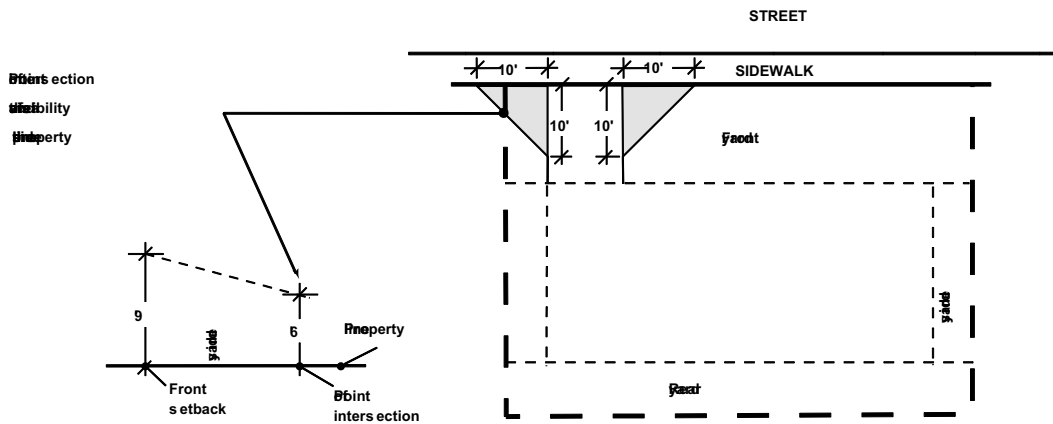

Diagram 142-03E

Combination Fence--Height Limit with Visibility Area



- (C) Vertical elements such as columns or posts shall be provided at least every 15 feet on a combination fence. Each vertical element shall be at least 6 inches wide (unfinished dimension), measured along the face of the fence as shown in Diagram 142-03F.
- (D) If wire fence material is used for the open portion of the fence, a horizontal element shall be provided along the top of the wire fence. This element shall be at least 1-½ inches wide with a minimum reveal of 1-½ inches, as shown in Diagram 142-03F.

Diagram 142-03F

Combination Fence--Vertical and Horizontal Elements

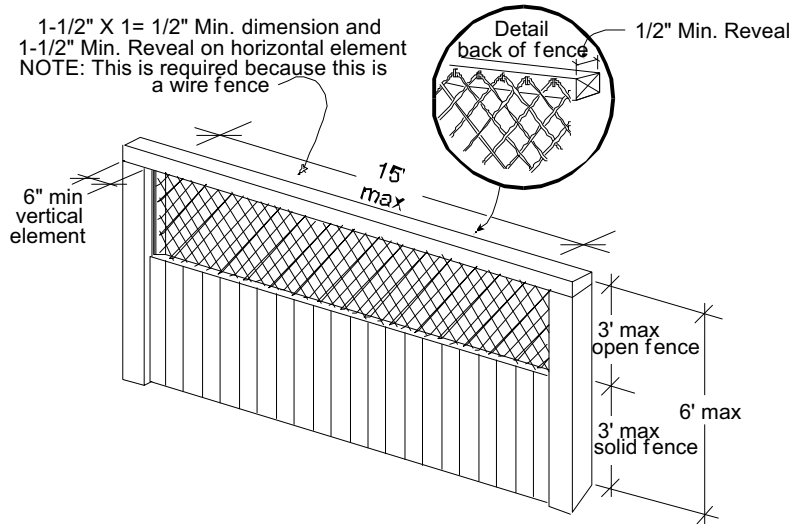

(4) Fence Height Exception in Required Street Side Yards

Solid fences located in the required *street side yard* of a *lot* with a rear yard that abuts the rear yard of another *lot*, as shown in Diagram 142-03G, are permitted up to 6 feet in height.

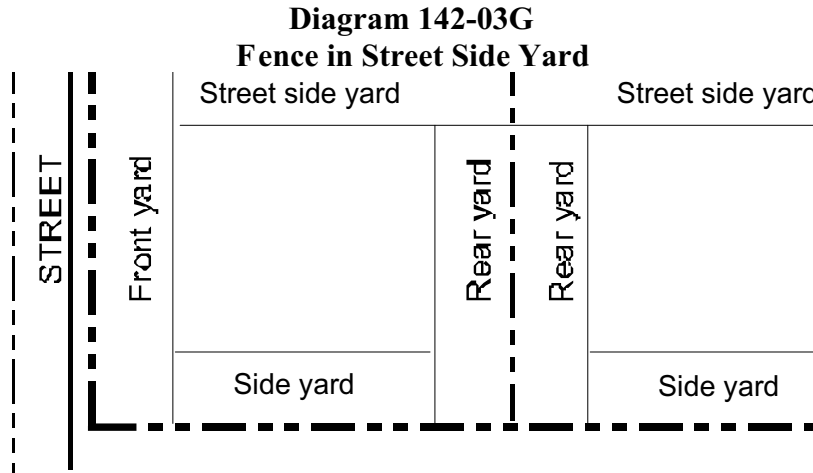

(d) *Fence Height in Required Side Yards and Required Rear Yards*

Fences located in required side yards and required rear yards are permitted up to 9 feet in height. Any portion of the *fence* above 6 feet in height shall be an *open fence*.

(e) *Fence Height Outside of Required Yards*

(1) *Fences* located outside of required yards, other than those listed in Section 142.0310(e)(2), shall not exceed 10 feet in height in open space, agricultural, and residential zones and 12 feet in height in commercial and industrial zones. These *fences* may be *solid fences*, *open fences*, or combination *fences*.

(2) The following *fences* are permitted outside of required yards up to the maximum *structure height* specified in the zone:

(A) *Open fences* enclosing tennis, badminton, volleyball, and other recreational and public facilities;

(B) Building, court, and wing walls or other integral portions of a building.

(Amended 1-9-2001 by O-18910 N.S.; effective 8-8-2001.)

(Amended 3-1-2006 by O-19467 N.S.; effective 8-10-2006.)

§142.0320 Exception to the General Fence Regulations for Residential Zones

In the Residential Townhouse (RT) zones, *fences* located in the required rear *yard* along an *alley* adjacent to a garage are permitted up to 10 feet in height. If a *roof deck* is located on the garage, the *fence* may extend to the height of the *roof deck* railing, provided that the *fence* design is consistent with that of the railing.
(Added 12-9-1997 by O-18451 N.S.; effective 1-1-2000.)

§142.0330 Exceptions to the General Fence Regulations for Commercial and Industrial Zones

(a) *Fences* in Required Rear *Yards* and Required Side *Yards*

- (1) *Solid fences* located in the required rear and side *yards* of commercially zoned property abutting a residentially zoned *lot* are permitted up to 9 feet in height.
- (2) *Solid fences* located in required rear and side *yards* of industrially zoned property are permitted up to 9 feet in height.

(b) Required *Fences*

- (1) A *solid fence* shall be constructed along all portions of commercially and industrially zoned *lots* that abut residentially zoned *lots*, unless there is a *grade* separation of more than 30 feet between the building pads of the abutting *lots*. Any gates provided in required *fences* shall also be solid. The *fence* and gate shall be 3 feet in height in required front and street side *yards* and shall be at least 6 feet but not more than 9 feet in height in required side and rear *yards*. If there is a *grade* difference of 30 feet or less between the building pads of the commercially or industrially zoned *lot* and the residentially zoned *lot*, the required 6-foot *fence* shall be located at the top of the slope between the two *lots*.
- (2) *Vehicular use areas* located in or adjacent to required front or street side *yards* shall be *screened* by a *fence* or landscaping of at least 3 feet in height. This *screen* shall be separated from the adjacent *public right-of-way* by a landscape strip that is at least 3 feet wide.

(Added 12-9-1997 by O-18451 N.S.; effective 1-1-2000.)