

Diagram 142-03D

Combination Fence--Height Limit

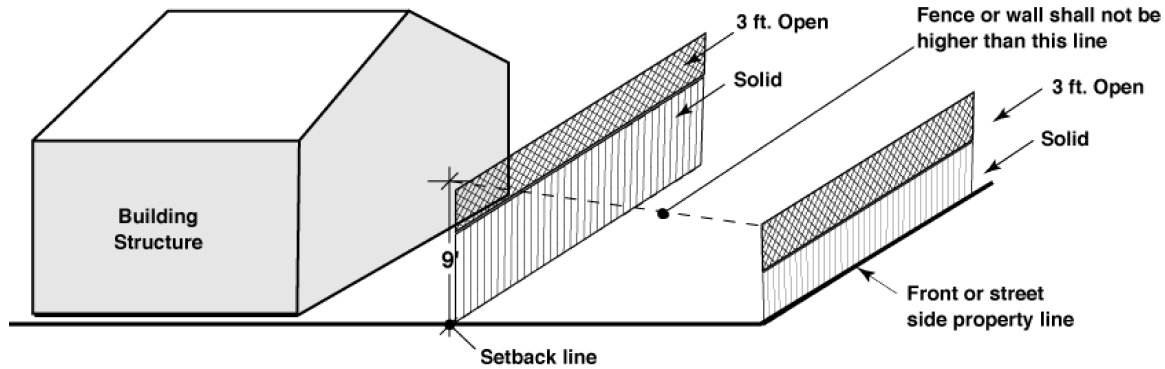
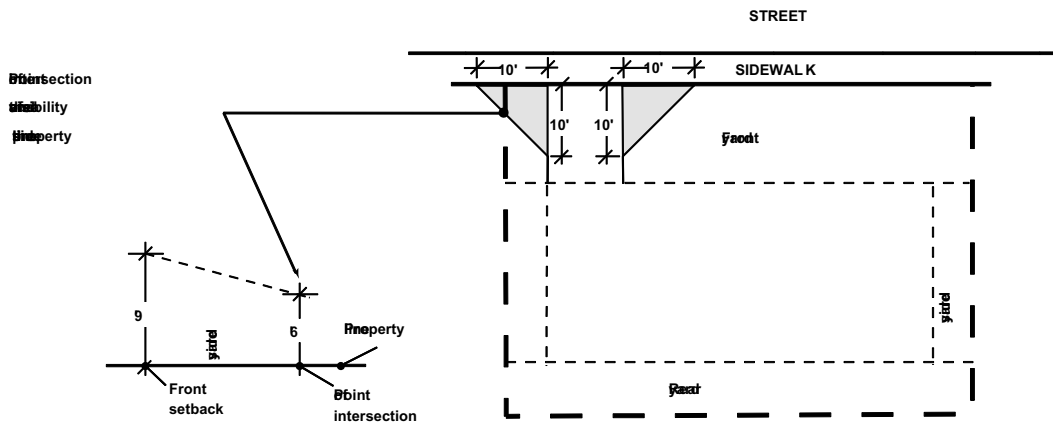

Diagram 142-03E

Combination Fence--Height Limit with Visibility Area



- (C) Vertical elements such as columns or posts shall be provided at least every 15 feet on a combination fence. Each vertical element shall be at least 6 inches wide (unfinished dimension), measured along the face of the fence as shown in Diagram 142-03F.
- (D) If wire fence material is used for the open portion of the fence, a horizontal element shall be provided along the top of the wire fence. This element shall be at least 1-½ inches wide with a minimum reveal of 1-½ inches, as shown in Diagram 142-03F.

Diagram 142-03F

Combination Fence--Vertical and Horizontal Elements

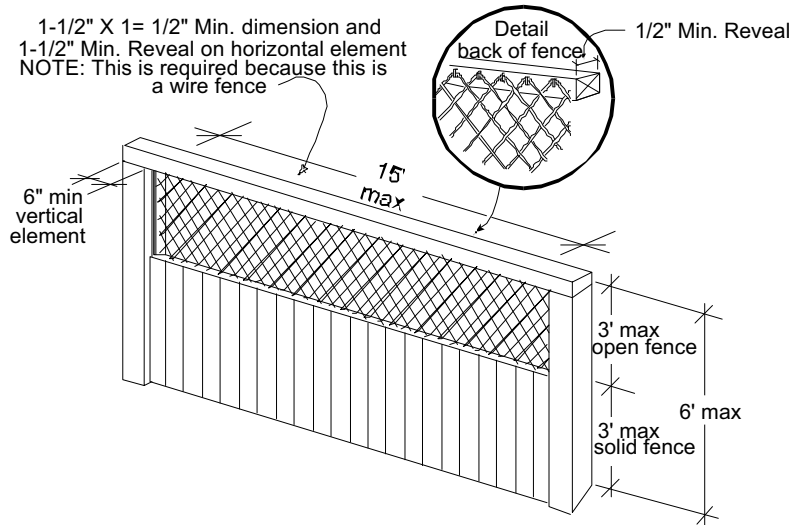

(4) *Fence Height Exception in Required Street Side Yards*

Solid fences located in the required *street side yard* of a *lot* with a rear *yard* that abuts the rear *yard* of another *lot*, as shown in Diagram 142-03G, are permitted up to 6 feet in height.