

**AGREEMENT FOR CONSTRUCTION AND MAINTENANCE OF
SAFETY IMPROVEMENTS RELATED TO QUIET ZONE**

**BNSF Secy. Cont. No: _____
San Diego Quiet Zone Project**

THIS AGREEMENT made and entered into this ____ day of _____, 2010, by and between the CITY OF SAN DIEGO, hereinafter referred to as "City", and the BNSF RAILWAY COMPANY, a Delaware corporation, hereinafter referred to as "BNSF". City and BNSF are collectively referred to as "Parties".

RECITALS

WHEREAS, BNSF owns a railroad line in and through the City which crosses at least five (5) City streets at-grade (the "Crossings") and over which trains are operated at all times of the day and night with safety features for motorists and pedestrians, including a system of warning signals and gates at crossings and the use of warning horns on trains; and

WHEREAS, the City is currently seeking authorization and approval from the California Public Utilities Commission ("CPUC") to construct certain safety improvements at the Crossings, as shown in Exhibit "A" attached hereto and incorporated herein by this references (the "Project"); and

WHEREAS, the City is desirous of creating a quiet zone as provided by the Federal Railroad Administration ("FRA") and 49 CFR Parts 222 and 229 of the Federal Register; and

WHEREAS, the establishment of the quiet zone is subject to the approval by the FRA pursuant to 49 CFR Parts 222 and 229; and

WHEREAS, BNSF and City agree to cooperate in the construction of the safety improvements; and

WHEREAS, the safety improvements are intended to be permanent improvements at the Crossings unless the Crossings are grade separated or closed to vehicular traffic; and

WHEREAS, BNSF and City are willing to undertake construction of the safety improvements at the City's sole cost and expense.

NOW, THEREFORE, in consideration of the mutual covenants and conditions hereinafter set forth, and subject to the approval of the Project by the CPUC, it is agreed as follows:

ATTACHMENT D

AGREEMENT

ARTICLE I

1. BNSF, at City's sole cost and expense, shall furnish all labor, materials, tools, and equipment and perform the railroad work required for construction of the safety improvements, such work and the estimated cost thereof being shown in Exhibit "B" attached hereto. The principal elements of the work to be performed by BNSF in the construction of the safety improvements shall include the following:

- a. Removal of existing signals and lights as shown on Exhibit "A";
- b. Construction and installation of the railroad signal active warning devices (with the exception of the vehicle detection system) as shown on Exhibit "A";
- c. Furnishing watchmen and flagmen as may be necessary for the safety of BNSF's property and the operation of its trains during the construction of the safety improvements.

2. BNSF agrees to perform all work provided in Article I, Section 1, with its own employees, working under Railroad Labor Agreements or by contractor(s), if necessary, within 18 months from receiving "Notice to Proceed" to be given in accordance with Article II, Section 10. BNSF shall determine the work windows, and has the right at any time to revise or change the work windows, due to train operations or service obligations. BNSF will not be responsible for any additional costs and expenses resulting from a change in work windows. Additional costs and expenses resulting from a change in work windows shall be accounted for in the City's expenses for the Project.

3. BNSF shall invoice the City annually for the cost of maintenance of the additional active warning devices located within BNSF's right-of-way as calculated in accordance with the formula set forth in Article II, Section 3 of this Agreement.

- a. Any reimbursement received by BNSF pursuant to California Public Utilities Code section 1202.2 for the cost of maintaining automatic grade-crossing protection for the crossings identified in Exhibit A shall first be applied towards BNSF's cost of maintaining the existing (non-Quiet Zone) crossing equipment. If such reimbursement exceeds the cost of maintaining the existing (non-Quiet Zone) crossing equipment, BNSF shall apply the remaining funds towards the cost of maintaining the Quiet Zone equipment, and reflect such credit in the annual invoices to the City.

4. BNSF is hereby authorized to include any extraordinary charge to cover the cost of BNSF's self-insurance expense covering Employer's Liability, including

liability under the Federal Employer's Liability Act, for protection of its employees in connection with the construction of the Project. Such charge will be included in Exhibit "B" and may not exceed the amount allowed by the Federal Highway Administration at the time of billing and shall be considered a portion of the actual cost of the Project regardless of the nature or amount of ultimate liability for injury, loss or death to BNSF's employees, if any.

5. In the event the estimates for the railroad work required for the Project are increased due to the passage of time or a change in the scope of the Project, City shall immediately provide BNSF with a credit enhancement sufficient to cover said increased estimates;

- a. Irrevocable Bank Letter of Credit drawn upon a bank satisfactory to BNSF;
- b. Surety Bond underwritten by an insurance company listed in the Department of Treasury Federal Register with terms acceptable to BNSF, in BNSF's sole discretion; or
- c. A posted cash deposit via wire transfer to a BNSF deposit account.

Any irrevocable letter of credit or surety bond provided to BNSF pursuant to this provision shall have a minimum term of eighteen (18) months. The bank issuing the letter of credit and the insurance company issuing the surety bond shall notify BNSF thirty (30) days prior to the expiration date of the letter of credit or the surety bond. Upon expiration of any surety bond or letter of credit, City must immediately provide BNSF with a substitute letter of credit, surety bond or cash deposit as set forth above until City's financial obligations to BNSF are fully and finally satisfied.

Any cash deposit provided under this provision will be held in a separate interest bearing account in the name of BNSF, with all interest accruing to City's benefit for use on the Project. If City's financial obligations at the end of the Project are less than the amount of the cash deposit, BNSF shall refund any remaining sum to City.

City should forward the letter of credit or the surety bond to Ted Johnson, Manager of Credit, BNSF, 2400 Western Center Boulevard, Fort Worth, Texas 76131 (phone: 817-352-4194). If posting a cash deposit pursuant to this provision, contact Ted Johnson to obtain the BNSF account information.

BNSF shall release any credit enhancement provided hereunder within thirty (30) days after payment of all funds due under Section 6 of this Article.

6 CITY FUNDING: The City shall pay BNSF for all actual labor costs, material costs, equipment costs, and other costs and expenses incurred by BNSF in performing the railroad work required for construction of the Project in a total amount not to exceed \$2,400,000.00. This amount consists of the estimated construction cost of \$1,830,535.00 as set forth in Exhibit "B", \$140,000 for flagging, and a construction

contingency fund of \$429,465.00. The construction contingency fund shall be used to reimburse BNSF if its actual construction costs exceed the estimated construction costs. If during the course of construction BNSF anticipates that its actual construction costs will exceed the estimated construction cost, BNSF shall promptly notify the City so additional funds can be appropriated to complete construction of the railroad work required for the Project. BNSF may discontinue construction activities until such time as the City notifies BNSF that sufficient additional funds have been appropriated. If the City fails to appropriate sufficient additional funds, BNSF may terminate this Agreement pursuant to Article III, section 3.

- a. Final Engineering, Design and Estimation. Reimbursement of the cost of preliminary signal engineering and design of the BNSF portion of the Project is provided for in the Memorandum of Understanding between Centre City Development Corporation (CCDC) and BNSF which was signed on February 27, 2008.
- b. Material Ordering. Concurrently with the giving of the Notice to Proceed in accordance with Article II, Section 10 of this Agreement, City will cut a check to BNSF for the cost of all material. Upon receipt of the check and the Notice to Proceed from the City, BNSF will order material and schedule the Project.
- c. Labor. BNSF will invoice the City for the labor portion of the Project sixty (60) days prior to start of construction. No construction will begin until payment is received by BNSF.
- d. Reconciliation. If BNSF's actual construction costs are less than the total estimated amount set forth in Exhibit B and advanced by the City in accordance with this section, BNSF will refund the difference to the City within 180 days after completion of the Project.

ARTICLE II

1. City, at its sole cost and expense, shall furnish all labor, materials, tools, and equipment and construct all safety improvements as shown in Exhibit "A", except for the railroad work to be performed by BNSF hereunder. The principal elements of the work to be performed by City in the construction of the safety improvements shall include the following:

- a. Obtaining from the CPUC an order authorizing and approving the construction of the safety improvements;
- b. Providing engineering, supervision, labor, material, supplies, and equipment necessary for construction of the safety improvements to be located outside of BNSF's right-of-way;

- c. Installation of the vehicle detection system;
- d. Installation of Advanced or Simultaneous pre-emption at highway traffic signals as noted on Exhibit "A";
- e. Installation of the roadway center medians;
- f. Construction of the roadway surface, including without limitation, curbs, gutters and fencing as shown on Exhibit "A".

2. City shall reimburse BNSF for the actual costs incurred by BNSF in constructing the safety improvements, as set forth in Article I, section 6.

3. City shall pay to BNSF the City's share of the annual Inspection, Maintenance costs for the following specific components of the Project's Safety Improvements in an amount not to exceed nine-thousand and twenty-seven dollars (\$9,027.00) for the first year the Project is in operation: (A) "Exit Gates 3 or 4 Quad" = 9 AAR units per gate mech., (B) "Exit Gate timing/logic controller" = 10 AAR units, (C) "Interconnection to road authority vehicle detection system", = 2 AAR units as invoiced pursuant to Article I, Section 3 of this Agreement. Costs have been calculated per Crossing Signal AAR unit to maintain highway/rail grade automated crossing warning systems. These costs are to be adjusted annually and the Parties agree to review the AAR units to ensure their appropriateness every three years. The City will annually appropriate funds sufficient to reimburse BNSF for the City's share of Inspection and Maintenance costs as estimated by BNSF. BNSF shall use its best efforts to provide the City with the estimated annual maintenance costs in time to be incorporated into the City's annual appropriations ordinance. If the City fails to appropriate sufficient funds, BNSF may terminate this Agreement pursuant to Article III, section 3.

Cost Break down:

- 1. Inspection/Maintenance of active warning device equipment:
 - a. 4 Quad System = $2 \times 9 \text{ AAR units} = 18 \text{ units} + 10 + 2 = 30 \text{ Units total}$
for 4 quad x average cost of \$177/unit = \$5,310
 - b. 3 Quad System = $1 \times 9 = 9 + 10 + 2 = 21 \text{ units} \times \$177/\text{unit} = \$3,717$
per each specific system noted above.
 - c. Inspection / Maintenance of systems includes all monthly inspections, and all trouble calls requiring the equipment to also be inspected or gates replaced (excessive gate replacement may be billed additional after a review is made by BNSF and City.
 - d. These costs will be billed to the City on an annual basis.

4. If the signal components of the Project are damaged due to an accident at the site, beyond the control of the parties, BNSF shall notify the City in writing with an estimate of the cost of repair. The City will reimburse BNSF for the actual cost to repair the components of the Project. If the City fails to reimburse BNSF, BNSF may terminate this Agreement pursuant to Article III, section 3.

- a. Capital. If the Crossing Signal Equipment and/or Crossing Signal House installed hereunder cannot, through age, be maintained, or by virtue of its obsolescence, requires replacement, the cost of installation of the new crossing signal equipment and/or new crossing signal house will be paid by the City.

5. City agrees to reimburse BNSF for work of an emergency nature caused by City or City's contractor, in connection with construction of the safety improvements which BNSF deems reasonably necessary for the immediate restoration of railroad operations or for the protection of persons or BNSF property. Such work may be performed by BNSF without prior approval of City and City agrees to fully reimburse BNSF for all reasonable costs of such emergency work. If the City fails to reimburse BNSF, BNSF may terminate this Agreement pursuant to Article III, section 3.

6. Except as expressly set forth in this Agreement, BNSF shall be responsible for all construction, reconstruction, operation, maintenance and repair costs related to its business activities.

7. City agrees to acquire all rights-of-way and permits necessary for the construction of the safety improvements.

8. City agrees to make any and all arrangements to secure the location or relocation of wire lines, pipe lines and other facilities owned by private persons, companies, corporations, political subdivisions or public utilities other than BNSF which may be found necessary to locate or relocate in any manner whatsoever due to the construction of the Project. Nothing in this Agreement shall be construed to modify the obligations, if any, of the City, BNSF and/or their respective contractors with regard to compliance with the requirements of California Government Code section 4216 et seq. for Project work which they perform.

9. The City, its contractor(s) and subcontractor(s), shall not begin Project work until City shall have given not less than thirty (30) days prior written notice to BNSF's Manager of Public Projects, making reference to BNSF's "San Diego Quiet Zone Project", which notice shall state the time that onsite Project work shall commence.

10. City must give BNSF's Manager of Public Projects written notice to proceed ("Notice to Proceed") with the railroad work after receipt of necessary funds for the Project. BNSF will not begin the railroad work (including, without limitation,

procurement of supplies, equipment or materials) until written notice to proceed is received from City. The Notice to Proceed must reference BNSF's file number "San Diego Quiet Zone".

ARTICLE III

1. This Agreement shall become effective on the date it is fully executed by all Parties to this Agreement, and shall remain in effect until terminated pursuant to this Article.

2. The City may, in its sole discretion, terminate this Agreement for its convenience at any time for any reason. The City shall pay all amounts due BNSF under Articles I and II of this Agreement up to the effective date of termination, and all reasonable costs incurred by BNSF in removing or mothballing equipment installed under this Agreement to implement the Quiet Zone. After the effective date of termination of the Quiet Zone, BNSF shall have no obligation to treat the Crossings as a Quiet Zone.

3. BNSF may terminate this Agreement, in its sole discretion, if the City fails to pay the amounts due BNSF under Articles I and II of this Agreement or fails to appropriate sufficient funds in its annual budget to reimburse BNSF to maintain the Quiet Zone. Prior to termination, BNSF shall send the City written notice of default and intent to terminate this Agreement, and provide the City with at least thirty (30) days to cure the default. If the City fails to cure the default within the time specified, BNSF may terminate this Agreement by sending the City written notice thereof. After the effective date of termination of the Quiet Zone, BNSF shall have no obligation to treat the Crossings as a Quiet Zone. The right to terminate this Agreement is in addition to any other remedies BNSF may have for the City's failure to pay amounts due under Articles I and II.

4. Upon the termination of this Agreement by either party, City shall immediately file a notice with the Federal Railroad Administration pursuant to 49 CFR § 222.51(d) voluntarily terminating the Quiet Zone effective thirty (30) days of the date of such notice.

ARTICLE IV

1. The City agrees to include the following provisions in its contract with any contractor performing construction and maintenance work on the Project in the BNSF right-of-way:

- a. Fiber optic cable systems owned by various telecommunications companies may cross or run parallel in the railroad operating right-of-way. The locations of these lines have been included on the plans based on

information from the telecommunications companies. The contractor shall be responsible to contact BNSF and/or the telecommunications companies regarding any work that may damage these facilities or interfere with their service. The contractor shall also pothole all lines either shown on the plans or marked in the field in order to verify their locations. The contractor shall also use all reasonable methods when working within the BNSF right-of-way to determine if any other fiber optic lines may exist;

- b. Failure to notify, pothole or identify these lines shall be sufficient cause for the City Engineer to stop construction at no cost to the City or BNSF until these items are completed. Costs for repairs and loss of revenues and profits due to damage to these facilities through negligent acts of the contractor shall be the sole responsibility of the contractor. The contractor shall indemnify and hold the City and BNSF harmless against and from all cost, liability and expense arising out of or in any way connected to the negligent acts of the contractor;
- c. The telecommunications companies shall be responsible for the rearrangement of any facilities determined to interfere with the construction. The contractor shall cooperate fully with any company performing these rearrangements.

2. The City shall incorporate in each prime contract for construction of the Project in, over or under the BNSF right-of-way, or the specifications therefore, the provisions set forth in Exhibits "C" and "C-I", attached hereto and by reference made a part hereof.

3. Except as hereinafter otherwise provided, all work to be performed hereunder by City in the construction of the Project will be performed pursuant to a contract or contracts to be let by City or performed by the City with its own forces. For work performed by contract, all such contracts shall provide:

- a. That all work performed thereunder shall be performed in a good and workmanlike manner, and in accordance with plans and specifications approved by BNSF. Those changes or modifications during construction that affect safety or BNSF's operations shall also be subject to BNSF's approval;
- b. That no work shall be commenced within BNSF's right-of-way until each of the prime contractors employed in connection with said work shall have (i) executed and delivered to BNSF a letter agreement in the form of Exhibit "C-I", and (ii) delivered to BNSF, and secured its approval of, the required insurance;

- c. That if the contractor has failed to prosecute with diligence the work specified in and by the terms of said contract, it may, in the manner provided by law, terminate the contractor's control over said work and take possession of all or any part thereof and proceed to complete the same by day labor or by employing another contractor(s), provided that all such contractor(s) shall be required to comply with the obligations in favor of BNSF hereinabove set forth and, provided further, that if such construction is performed by day labor, City will, at its expense, procure and maintain on behalf of BNSF the insurance required by Exhibit "C-1".

4. If any City Contractor performs construction work within the BNSF right-of-way contrary to the Plans and Specifications or if any City Contractor performs construction work within the BNSF right-of-way in a manner BNSF deems to be hazardous to its property, facilities or the safe and expeditious movement of its traffic, or if the insurance described in said Exhibit "C-1" hereof shall be canceled during the course of the Project, BNSF shall have the right to stop the work within the BNSF right-of-way until the acts or omissions of such City Contractor have been fully rectified to the satisfaction of the BNSF's Division Engineer, or additional insurance has been delivered to and accepted by BNSF. Such work stoppage shall not give rise to or impose upon BNSF any liability to City, or to any City Contractor. The right of BNSF to stop the work is in addition to any other rights BNSF may have. In the event that BNSF shall desire to stop work, BNSF agrees to give immediate notice thereof in writing to the City representative identified in Article IV, Section 13 of this Agreement, describing the reason(s) for the work stoppage.

5. The City shall supervise and inspect the operations of all City contractors working within BNSF's right-of-way to assure compliance with the Project plans and specifications, the terms of this Agreement and all safety requirements of BNSF. If at any time during construction within BNSF's right-of-way BNSF determines that the proper supervision and inspection is not being performed by the City, BNSF shall have the right to stop construction (within or immediately adjacent to its right-of-way) and to request that the City correct the situation before construction is allowed to proceed. If BNSF feels the situation is not being corrected in an expeditious manner, BNSF shall immediately notify the City's Director of Public Works for appropriate corrective action.

6. City's contractor(s) and subcontractor(s) shall perform and complete work in a manner that does not interfere with the normal movement of trains and according to contractor's own manner and methods and with and by contractor(s)' and subcontractor(s)' own means and employees, free from any supervision, inspection, or control whatsoever by BNSF, except that BNSF shall have the right to inspect City's contractor(s)' or subcontractor(s)' work to determine whether the work performed complies with the requirements of this Agreement, it being the intention of the Parties that the contractor(s) and subcontractor(s) shall be and remain independent contractor(s) and subcontractor(s) and that nothing contained in this Agreement shall be construed as inconsistent with that status. City shall require its contractors and their subcontractors constructing any of the safety improvements within BNSF's right-of-way

to execute and comply with all Contractor Requirements, as set forth in Exhibit "C" hereto.

7. City shall require its contractor(s) and subcontractor(s) to comply with all applicable federal, state and local requirements and regulations with respect to the performance of Project work. To the extent that any City contractor or subcontractor performs work in BNSF's right-of-way, BNSF may advise such contractor or subcontractor, or contractor's or subcontractor's work site supervisor, that an agent or employee of the contractor or subcontractor is working in an unsafe manner or may potentially work in an unsafe manner, in which event such contractor's or subcontractors' work site supervisor shall cause the agent or employee to immediately correct the problem or leave the work site and BNSF's property.

8. The Parties agree that after completion of the safety improvements, BNSF shall maintain and operate all crossing gates and signals. City shall reimburse BNSF for maintenance of the safety improvements constructed pursuant to this Agreement as herein provided.

9. The Parties agree that after completion of the safety improvements, the City will own and maintain at the City's sole cost and expense the vehicle detection in-pavement loops to the gate mechanism mounted junction box. BNSF will own and maintain, at City's sole cost and expense, the cable from the gate mechanism mounted junction box to the vehicle loop detection electronics, as well as the loop detection electronics (BNSF trackage only). The City will provide a contact number for loop failures/quiet zone and/or preemption issues. This number should be monitored 24 hours per day, 7 days per week. At such time as the Vehicle Detection System is placed in service, the City will have procedures in place for emergency loop replacement both during and after normal working hours. The City will reimburse BNSF for the ongoing maintenance and repair costs of that portion of the Vehicle Detection System to be maintained by BNSF as provided herein.

- a. In the event of a failure of the vehicle detection system to function as designed, the City shall immediately provide a flagman for each direction of motor vehicle traffic at the City's sole cost and expense. If the City fails to immediately provide flagging services in accordance with the previous sentence, BNSF shall have the right to provide such flagging services at the City's sole cost and expense. For the duration of the time in which the vehicle detection system fails to function as designed, the train horn shall be sounded as required by 49 CFR §234.106.
- b. City shall provide BNSF with a minimum of 4 hours advance telephonic notice of any vehicle detection maintenance activity that may cause any electrical disruption in the Vehicle Detection System, including, but not limited to: (i) work that involves turning off power or resetting the vehicle detection signal controller; (ii) work that disrupts the connection between the vehicle detection signal controller and the vehicle detection loops; or

(iii) work that disrupts the connection between the vehicle detection signal controller and the BNSF interconnection box. Such notice shall be given using BNSF's toll free number (800) 382-5452.

10. The Parties agree that if BNSF deems it necessary or desirable in the performance of its duty as a common carrier, to raise or lower the grade or change the alignment of its tracks or to lay additional track or tracks or to build other facilities in connection with the operation of its railroad, BNSF shall, at its own expense, have full right to make such changes or additions within its right of way, provided such changes or additions do not change or alter the safety improvements and provided further, however, that should it become necessary or desirable in the future to change, alter, widen, or reconstruct the safety improvements to accommodate BNSF railroad projects, the costs of such work, including any cost incidental to alteration of railroad or highway facilities made necessary by the alteration of the safety improvements, shall be paid by BNSF.

- a. Notwithstanding the foregoing, nothing in this Agreement shall be construed as waiving or conditioning the right of the City to object to any effort by BNSF to change the grade or track alignment in any way that would impact (a) the City's interests in or use of adjacent right-of-way or (b) the use of the at-grade crossings that are the subject of this Agreement.

11. The Parties agree that if City shall deem it necessary or desirable in the future, due to traffic or other conditions, to alter or reconstruct the safety improvements, it shall have full right to do so, at City's own expense and subject to CPUC approval, provided, however, that such alteration or reconstruction shall not encroach further upon or occupy the surface of BNSF's right-of-way to a greater extent than is contemplated by this Agreement without the prior CPUC approval and written consent of BNSF and the execution of an amendment to this Agreement or the completion of a separate written agreement.

12. The books, papers, records and accounts of the Parties hereto, insofar as they relate to the items of expense for labor and materials or are in any way connected with the work herein contemplated, shall be retained and at all reasonable times be open to inspection and audit by the agents and authorized representatives of the other Party hereto, and representatives of governmental agencies as required by law, for a period of four (4) years from the date of final payment. Upon completion of the Project, City, and/or representatives of governmental agencies as required by law, may assign an auditor to review and report on BNSF and City's time sheets and financial records related to this Project. BNSF and City shall work with such auditors to reconcile excepted costs that may arise from any audit. All books, records and accounts relating to the maintenance and repair costs which are the subject of an invoice pursuant to Article II shall be retained and open to inspection and audit by agents and authorized representatives of the City for a period of four (4) years from the date that BNSF provides such invoice to the City.

13. All notices shall be in writing and shall be considered given either: (i) when delivered in person to the recipient named below; or (ii) on the date of delivery or refusal shown on the return receipt, after deposit in the United States mail in a sealed envelope as either registered or certified mail with return receipt requested, and postage and postal charges prepaid; (iii) on the date of delivery or refusal, when delivered by Federal Express or other commercial express delivery service providing acknowledgements of receipt; or (iv) on the date of delivery when delivered by facsimile or other electronic transmission providing verification of delivery and receipt. Such notices or communications shall be given to the Parties at their addresses set forth below:

To BNSF: BNSF Railway Company
Vice-President and Chief Engineer
2600 Lou Menk Drive
Fort Worth, TX 76131

With Copy To: BNSF Railway Company
Manager of Public Projects
740 East Carnegie Drive
San Bernardino, CA 92408-3571

To City: City of San Diego
City Engineer
202 C Street
San Diego, CA 92101

With Copy To: Centre City Development Corporation
Attn: Scott A. Johnson
401 B Street, Suite 400
San Diego, California 92101

And to: City Attorney
San Diego City Attorney's Office
1200 Third Avenue, Suite 1620
San Diego, CA 92101

Either Party may change its address for notices by written notice to the other Party given in the manner provided in this section.

14. Exhibits "A", "B", "C" and "C-1" attached hereto, are an integral part of this Agreement and shall be construed for all purposes as a part of this Agreement.

15. The venue for any action to enforce or interpret this Agreement shall lie in the Superior Court for the County of San Diego or the District Court for the Southern District of California, as appropriate.

16. Any waiver by the Parties of any default or breach of any covenant, condition, or term contained in this Agreement shall not be construed to be a waiver of any subsequent or other default or breach, nor shall the failure to require exact, full, and complete compliance with any of the covenants, conditions, or terms contained in this Agreement be construed as changing the terms of this Agreement in any manner or preventing the enforcement of the full provisions hereof.

17. If any action at law or in equity is necessary to enforce or interpret the terms of this Agreement, the prevailing Party shall be entitled to reasonable attorney's fees and costs.

18. This Agreement constitutes the entire understanding and agreement of the Parties hereto and supersedes all previous negotiations, discussions, and agreements between the Parties with respect to the subject matter hereof. No parol evidence shall be permitted to contradict or vary the terms of this Agreement.

19. Whenever possible, each provision of this Agreement shall be interpreted in such a manner as to be effective and valid under applicable law, but if any provision of this Agreement shall be invalid under the applicable law, such provision shall be ineffective only to the extent of such prohibition or invalidity, without invalidating the remainder of that provision, or the remaining provisions of this Agreement.

20. The Parties agree that all of the covenants and provisions of this Agreement shall be binding upon and inure to the benefit of the Parties' successors and assigns, except that neither City nor BNSF may assign any of its rights or obligations hereunder without the prior written consent of the other party, which consent shall not be unreasonably withheld.

21. The Recitals above are hereby incorporated into this section as though fully set forth herein and each party acknowledges and agrees that such Party is bound, for purposes of this Agreement, by the same.

22. Each of the undersigned represents and warrants that he or she is duly authorized to execute and deliver this Agreement and that such execution is binding upon the entity for which he or she is executing this document.

23. To the fullest extent permitted by law, City hereby releases, indemnifies, defends and holds harmless BNSF, its affiliated companies, partners, successors, assigns, legal representatives, officers, directors, shareholders, employees and agents for, from and against any and all claims, liabilities, fines, penalties, costs, damages, losses, liens, causes of action, suits, demands, judgments and expenses (including, without limitation, court costs and attorneys' fees) of any nature, kind or description of any person (including, without limitation, the employees of the parties hereto) or entity to the extent such claims, liabilities, fines, penalties, costs, damages, losses, liens, causes of action, suits, demands, judgments and expenses arise directly out of, result from or are related to the acts or omissions of City, its officers, agents, invitees, employees or

contractors or anyone directly or indirectly employed by any of them, or others performing services in furtherance of the construction or maintenance of the safety improvements or the operation of the Quiet Zone.

- a. City shall also defend, indemnify and hold harmless BNSF, its affiliated companies, partners, successors, assigns, legal representatives, officers, directors, shareholders, employees and agents from and against any claims, liabilities, fines, penalties, costs, damages, losses, liens, causes of action, suits, demands, judgments and expenses (including, without limitation, court costs and attorneys' fees) of any nature, kind or description of any person alleging the Quiet Zone causes additional noise from the BNSF gate crossing bells, or that the Quiet Zone causes additional traffic delays or diminution in property value as it relates to BNSF's operation within the Quiet Zone.

24. The City shall be self-insured for its general liability coverage up to \$4 million. The City shall participate in large risk pool CSAC-EIA/CPEIA coverage which provides excess coverage from \$4 million to \$15 million, or in a similar program of insurance providing these limits and scope of coverage. The City will maintain excess coverage beyond the limits of the pool coverage with total limits of \$50 million. The City may determine from time to time to increase the amount of self-insurance coverage. If the City makes a determination to increase the self-insurance amount, the large risk pool coverage will apply over the self-insurance amount. The City shall remove any exclusions relating to performance of operations within the vicinity of any railroad, bridge, trestle, track, roadbed, tunnel, underpass, or crossing from its general liability coverage for both the self insured and excess policies, or purchase a separate railroad protective liability policy. If a separate railroad protective liability policy is purchased it shall be in an amount of at least \$5,000,000. The insurance policies shall name BNSF, its directors, officers, agents and employees as additional insureds, and be primary to any insurance carried by BNSF.

25. The Redevelopment Agency and/or CCDC may make some or all of payments due BNSF under the terms of this Agreement on behalf of the City, except for annual maintenance costs under Article 1, Section 3 of this Agreement. BNSF will accept such payment in lieu of direct payment by the City. BNSF's acceptance of such payment shall not relieve the City of its obligation to ensure BNSF receives all payment due under this Agreement.

IN WITNESS WHEREOF, this Agreement is executed by the City of San Diego, acting by and through its Mayor or his designee, pursuant to Ordinance No. O-_____ authorizing such execution, and by BNSF attested by its duly qualified and authorized officials as of the date first hereinabove written.

BNSF RAILWAY COMPANY

CITY OF SAN DIEGO

By: _____
David Freeman
Vice President of Engineering

By: _____
Jay Goldstone
Chief Operating Officer

Date: _____

Date: _____

I HEREBY APPROVE the form and legality of the foregoing agreement this _____ day of _____, 2010.

JAN I. GOLDSMITH, City Attorney

By: _____
Deputy City Attorney

Exhibit A (1 of 6)

Index and Legend

REV.	DATE	DESCRIPTION	BY	APP.



RAILPROS INC.
 18700 CONCORD DRIVE, SUITE H
 FALLBROOK, CA 92038
 PHONE: 619.429.7100
 FAX: 619.429.7100

**DOWNTOWN SAN DIEGO
 QUIET ZONE
 SAN DIEGO, CA**

EXHIBIT A
INDEX AND LEGEND
 SCALE: _____ SIZE: 11"x17"
 DESIGNED: DJM DRAWN: JG CHECKED: EH DATE: MAR. 28, 2007
SHEET 1 OF 13

SHEET INDEX

SHT. NO.	SHEET TITLE
1	INDEX AND LEGEND
2	EXISTING SIGNAL
3	PROPOSED SIGNAL
4	EXISTING TRACK
5	PROPOSED TRACK
6	EXISTING SIDEWALK
7	PROPOSED SIDEWALK
8	EXISTING ASPHALT
9	PROPOSED ASPHALT
10	EXISTING CONCRET
11	PROPOSED CONCRET
12	EXISTING CURB AND GUTTER
13	PROPOSED CURB AND GUTTER

LEGEND

- 1 REMOVE
- 2 ADD
- 3 EXISTING, PROJECT IN PLACE
- 4 RELOCATE
- 5 CCCC CIVIL CONTRACT - 3 DIGIT CALLOUT SERIES
- 6 PROPOSED
- 7 REMOVED
- 8 PROPOSED
- 9 REMOVED
- 10 EXISTING
- 11 PROPOSED
- 12 EXISTING
- 13 PROPOSED
- 14 CURB AND GUTTER
- 15 SIDEWALK
- 16 FENCE - 4" HIGH
- 17 FENCE - 8" HIGH
- 18 FENCE - 12" HIGH
- 19 FENCE - 16" HIGH
- 20 FENCE - 20" HIGH
- 21 FENCE - 24" HIGH
- 22 FENCE - 28" HIGH
- 23 FENCE - 32" HIGH
- 24 FENCE - 36" HIGH
- 25 FENCE - 40" HIGH
- 26 FENCE - 44" HIGH
- 27 FENCE - 48" HIGH
- 28 FENCE - 52" HIGH
- 29 FENCE - 56" HIGH
- 30 FENCE - 60" HIGH
- 31 FENCE - 64" HIGH
- 32 FENCE - 68" HIGH
- 33 FENCE - 72" HIGH
- 34 FENCE - 76" HIGH
- 35 FENCE - 80" HIGH
- 36 FENCE - 84" HIGH
- 37 FENCE - 88" HIGH
- 38 FENCE - 92" HIGH
- 39 FENCE - 96" HIGH
- 40 FENCE - 100" HIGH
- 41 FENCE - 104" HIGH
- 42 FENCE - 108" HIGH
- 43 FENCE - 112" HIGH
- 44 FENCE - 116" HIGH
- 45 FENCE - 120" HIGH
- 46 FENCE - 124" HIGH
- 47 FENCE - 128" HIGH
- 48 FENCE - 132" HIGH
- 49 FENCE - 136" HIGH
- 50 FENCE - 140" HIGH
- 51 FENCE - 144" HIGH
- 52 FENCE - 148" HIGH
- 53 FENCE - 152" HIGH
- 54 FENCE - 156" HIGH
- 55 FENCE - 160" HIGH
- 56 FENCE - 164" HIGH
- 57 FENCE - 168" HIGH
- 58 FENCE - 172" HIGH
- 59 FENCE - 176" HIGH
- 60 FENCE - 180" HIGH
- 61 FENCE - 184" HIGH
- 62 FENCE - 188" HIGH
- 63 FENCE - 192" HIGH
- 64 FENCE - 196" HIGH
- 65 FENCE - 200" HIGH
- 66 FENCE - 204" HIGH
- 67 FENCE - 208" HIGH
- 68 FENCE - 212" HIGH
- 69 FENCE - 216" HIGH
- 70 FENCE - 220" HIGH
- 71 FENCE - 224" HIGH
- 72 FENCE - 228" HIGH
- 73 FENCE - 232" HIGH
- 74 FENCE - 236" HIGH
- 75 FENCE - 240" HIGH
- 76 FENCE - 244" HIGH
- 77 FENCE - 248" HIGH
- 78 FENCE - 252" HIGH
- 79 FENCE - 256" HIGH
- 80 FENCE - 260" HIGH
- 81 FENCE - 264" HIGH
- 82 FENCE - 268" HIGH
- 83 FENCE - 272" HIGH
- 84 FENCE - 276" HIGH
- 85 FENCE - 280" HIGH
- 86 FENCE - 284" HIGH
- 87 FENCE - 288" HIGH
- 88 FENCE - 292" HIGH
- 89 FENCE - 296" HIGH
- 90 FENCE - 300" HIGH
- 91 FENCE - 304" HIGH
- 92 FENCE - 308" HIGH
- 93 FENCE - 312" HIGH
- 94 FENCE - 316" HIGH
- 95 FENCE - 320" HIGH
- 96 FENCE - 324" HIGH
- 97 FENCE - 328" HIGH
- 98 FENCE - 332" HIGH
- 99 FENCE - 336" HIGH
- 100 FENCE - 340" HIGH
- 101 FENCE - 344" HIGH
- 102 FENCE - 348" HIGH
- 103 FENCE - 352" HIGH
- 104 FENCE - 356" HIGH
- 105 FENCE - 360" HIGH
- 106 FENCE - 364" HIGH
- 107 FENCE - 368" HIGH
- 108 FENCE - 372" HIGH
- 109 FENCE - 376" HIGH
- 110 FENCE - 380" HIGH
- 111 FENCE - 384" HIGH
- 112 FENCE - 388" HIGH
- 113 FENCE - 392" HIGH
- 114 FENCE - 396" HIGH
- 115 FENCE - 400" HIGH
- 116 FENCE - 404" HIGH
- 117 FENCE - 408" HIGH
- 118 FENCE - 412" HIGH
- 119 FENCE - 416" HIGH
- 120 FENCE - 420" HIGH
- 121 FENCE - 424" HIGH
- 122 FENCE - 428" HIGH
- 123 FENCE - 432" HIGH
- 124 FENCE - 436" HIGH
- 125 FENCE - 440" HIGH
- 126 FENCE - 444" HIGH
- 127 FENCE - 448" HIGH
- 128 FENCE - 452" HIGH
- 129 FENCE - 456" HIGH
- 130 FENCE - 460" HIGH
- 131 FENCE - 464" HIGH
- 132 FENCE - 468" HIGH
- 133 FENCE - 472" HIGH
- 134 FENCE - 476" HIGH
- 135 FENCE - 480" HIGH
- 136 FENCE - 484" HIGH
- 137 FENCE - 488" HIGH
- 138 FENCE - 492" HIGH
- 139 FENCE - 496" HIGH
- 140 FENCE - 500" HIGH
- 141 FENCE - 504" HIGH
- 142 FENCE - 508" HIGH
- 143 FENCE - 512" HIGH
- 144 FENCE - 516" HIGH
- 145 FENCE - 520" HIGH
- 146 FENCE - 524" HIGH
- 147 FENCE - 528" HIGH
- 148 FENCE - 532" HIGH
- 149 FENCE - 536" HIGH
- 150 FENCE - 540" HIGH
- 151 FENCE - 544" HIGH
- 152 FENCE - 548" HIGH
- 153 FENCE - 552" HIGH
- 154 FENCE - 556" HIGH
- 155 FENCE - 560" HIGH
- 156 FENCE - 564" HIGH
- 157 FENCE - 568" HIGH
- 158 FENCE - 572" HIGH
- 159 FENCE - 576" HIGH
- 160 FENCE - 580" HIGH
- 161 FENCE - 584" HIGH
- 162 FENCE - 588" HIGH
- 163 FENCE - 592" HIGH
- 164 FENCE - 596" HIGH
- 165 FENCE - 600" HIGH
- 166 FENCE - 604" HIGH
- 167 FENCE - 608" HIGH
- 168 FENCE - 612" HIGH
- 169 FENCE - 616" HIGH
- 170 FENCE - 620" HIGH
- 171 FENCE - 624" HIGH
- 172 FENCE - 628" HIGH
- 173 FENCE - 632" HIGH
- 174 FENCE - 636" HIGH
- 175 FENCE - 640" HIGH
- 176 FENCE - 644" HIGH
- 177 FENCE - 648" HIGH
- 178 FENCE - 652" HIGH
- 179 FENCE - 656" HIGH
- 180 FENCE - 660" HIGH
- 181 FENCE - 664" HIGH
- 182 FENCE - 668" HIGH
- 183 FENCE - 672" HIGH
- 184 FENCE - 676" HIGH
- 185 FENCE - 680" HIGH
- 186 FENCE - 684" HIGH
- 187 FENCE - 688" HIGH
- 188 FENCE - 692" HIGH
- 189 FENCE - 696" HIGH
- 190 FENCE - 700" HIGH
- 191 FENCE - 704" HIGH
- 192 FENCE - 708" HIGH
- 193 FENCE - 712" HIGH
- 194 FENCE - 716" HIGH
- 195 FENCE - 720" HIGH
- 196 FENCE - 724" HIGH
- 197 FENCE - 728" HIGH
- 198 FENCE - 732" HIGH
- 199 FENCE - 736" HIGH
- 200 FENCE - 740" HIGH
- 201 FENCE - 744" HIGH
- 202 FENCE - 748" HIGH
- 203 FENCE - 752" HIGH
- 204 FENCE - 756" HIGH
- 205 FENCE - 760" HIGH
- 206 FENCE - 764" HIGH
- 207 FENCE - 768" HIGH
- 208 FENCE - 772" HIGH
- 209 FENCE - 776" HIGH
- 210 FENCE - 780" HIGH
- 211 FENCE - 784" HIGH
- 212 FENCE - 788" HIGH
- 213 FENCE - 792" HIGH
- 214 FENCE - 796" HIGH
- 215 FENCE - 800" HIGH
- 216 FENCE - 804" HIGH
- 217 FENCE - 808" HIGH
- 218 FENCE - 812" HIGH
- 219 FENCE - 816" HIGH
- 220 FENCE - 820" HIGH
- 221 FENCE - 824" HIGH
- 222 FENCE - 828" HIGH
- 223 FENCE - 832" HIGH
- 224 FENCE - 836" HIGH
- 225 FENCE - 840" HIGH
- 226 FENCE - 844" HIGH
- 227 FENCE - 848" HIGH
- 228 FENCE - 852" HIGH
- 229 FENCE - 856" HIGH
- 230 FENCE - 860" HIGH
- 231 FENCE - 864" HIGH
- 232 FENCE - 868" HIGH
- 233 FENCE - 872" HIGH
- 234 FENCE - 876" HIGH
- 235 FENCE - 880" HIGH
- 236 FENCE - 884" HIGH
- 237 FENCE - 888" HIGH
- 238 FENCE - 892" HIGH
- 239 FENCE - 896" HIGH
- 240 FENCE - 900" HIGH
- 241 FENCE - 904" HIGH
- 242 FENCE - 908" HIGH
- 243 FENCE - 912" HIGH
- 244 FENCE - 916" HIGH
- 245 FENCE - 920" HIGH
- 246 FENCE - 924" HIGH
- 247 FENCE - 928" HIGH
- 248 FENCE - 932" HIGH
- 249 FENCE - 936" HIGH
- 250 FENCE - 940" HIGH
- 251 FENCE - 944" HIGH
- 252 FENCE - 948" HIGH
- 253 FENCE - 952" HIGH
- 254 FENCE - 956" HIGH
- 255 FENCE - 960" HIGH
- 256 FENCE - 964" HIGH
- 257 FENCE - 968" HIGH
- 258 FENCE - 972" HIGH
- 259 FENCE - 976" HIGH
- 260 FENCE - 980" HIGH
- 261 FENCE - 984" HIGH
- 262 FENCE - 988" HIGH
- 263 FENCE - 992" HIGH
- 264 FENCE - 996" HIGH
- 265 FENCE - 1000" HIGH

Exhibit A (2 of 6)

Kettner Boulevard/G Street – DOT 026874D MP 267.8 – San Diego Subdivision

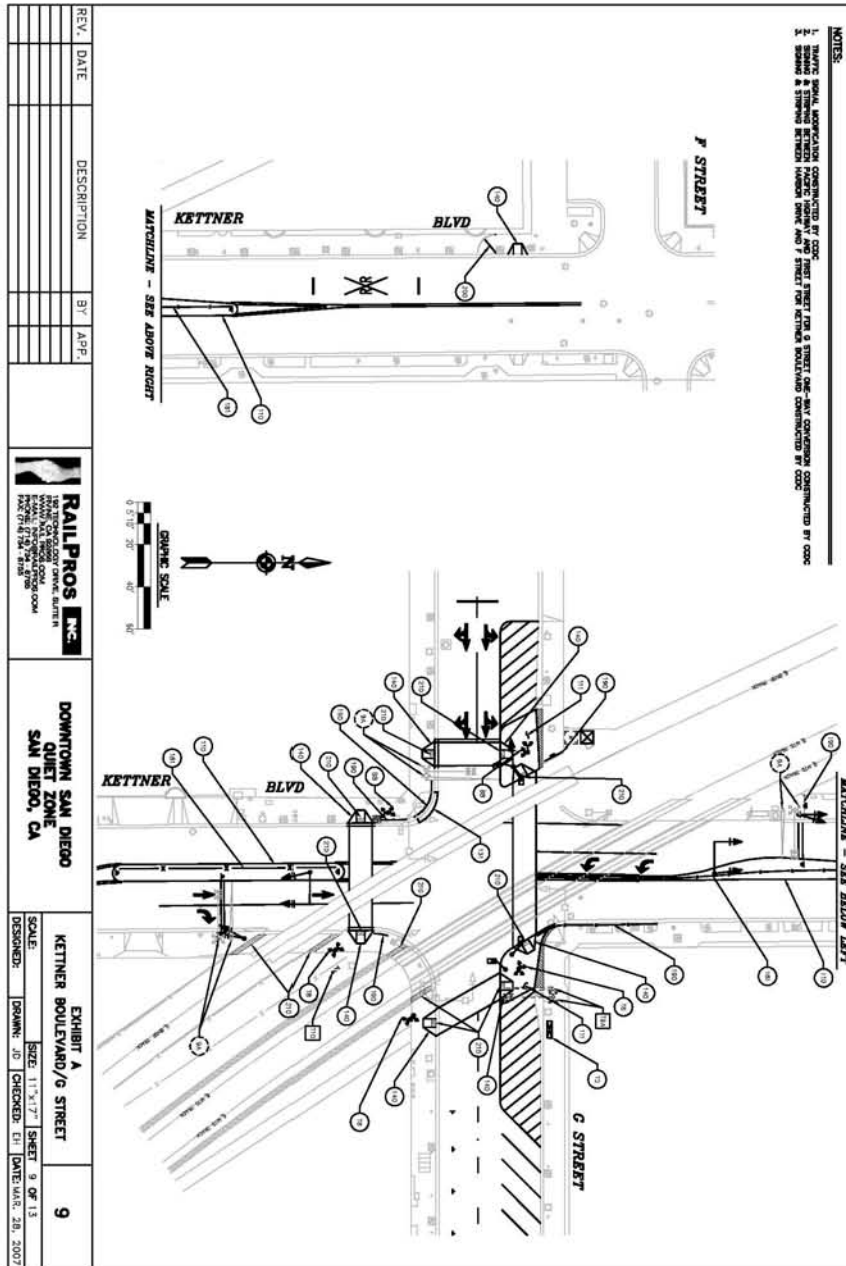

Exhibit A (3 of 6)

Market Street – DOT 026875K MP 267.9 – San Diego Subdivision

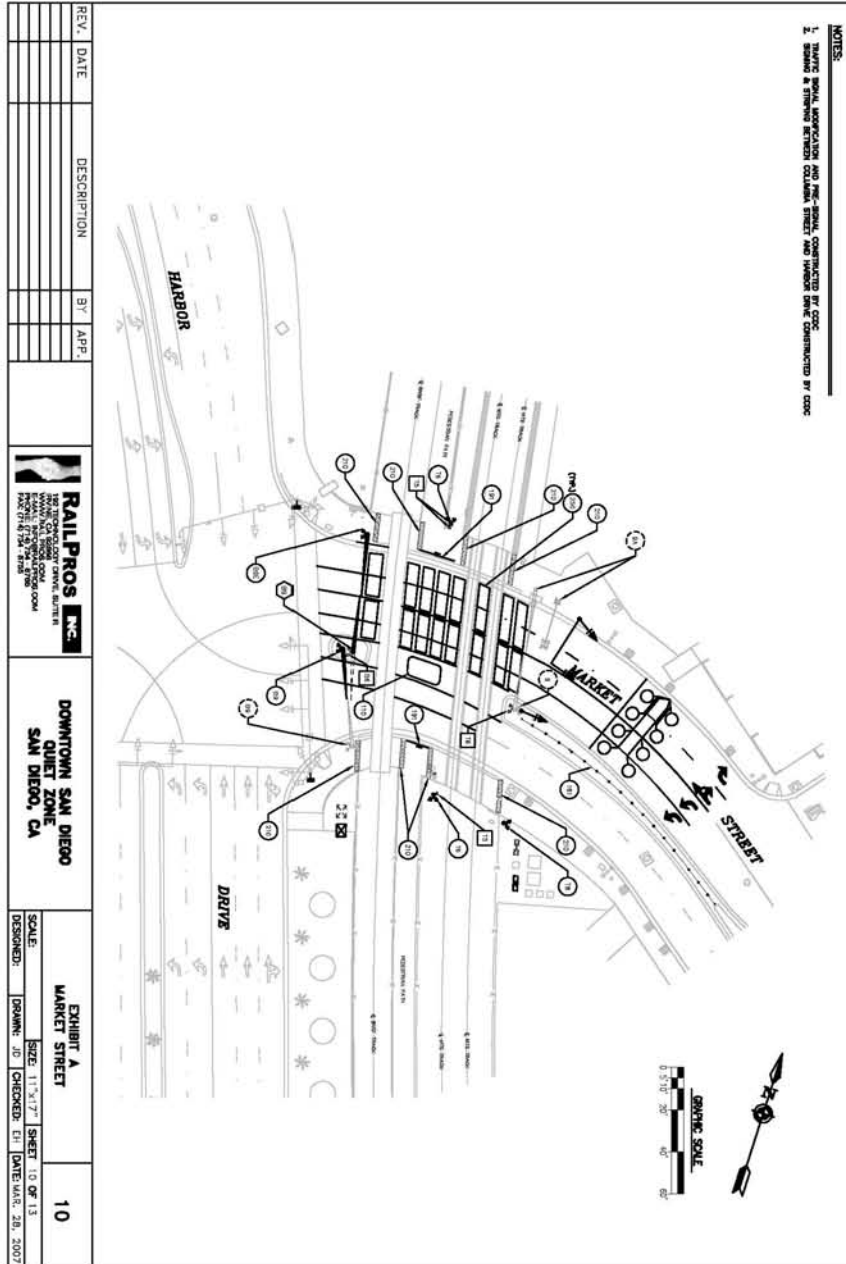

Exhibit A (4 of 6)

Front Street MP 268.2 – San Diego Subdivision

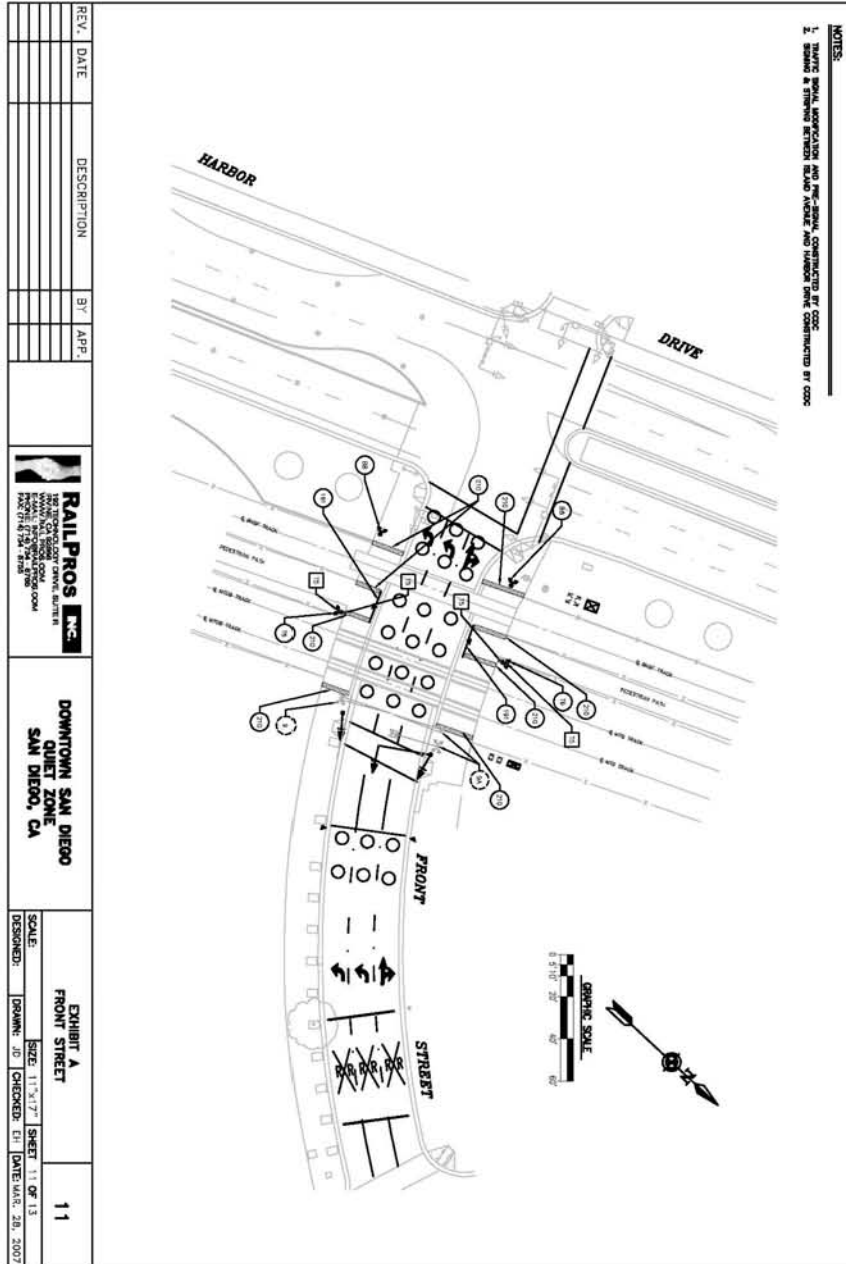

Exhibit A (5 of 6)

First Street – DOT 026877Y MP 268.3 – San Diego Subdivision

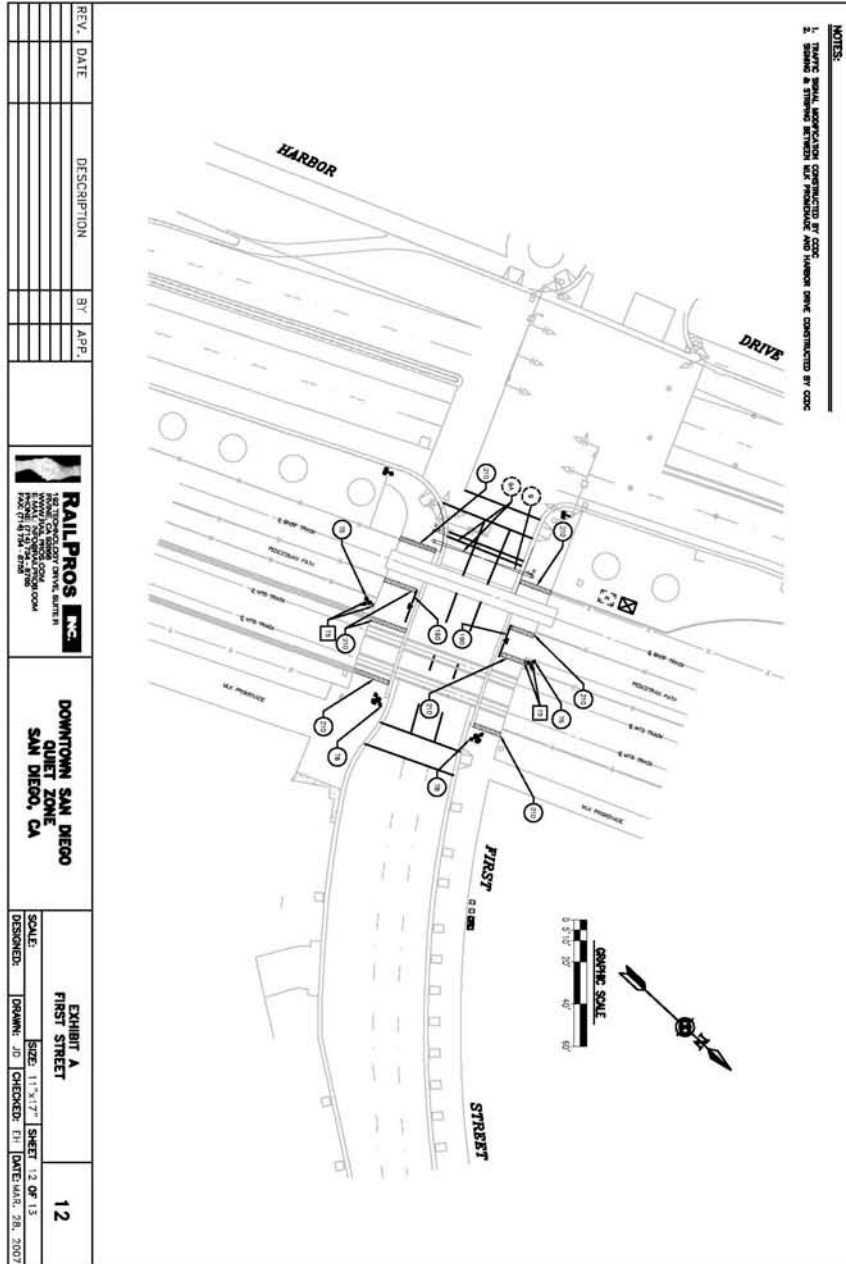

Exhibit A (6 of 6)

Fifth Street – DOT 026878F MP 268.5 – San Diego Subdivision

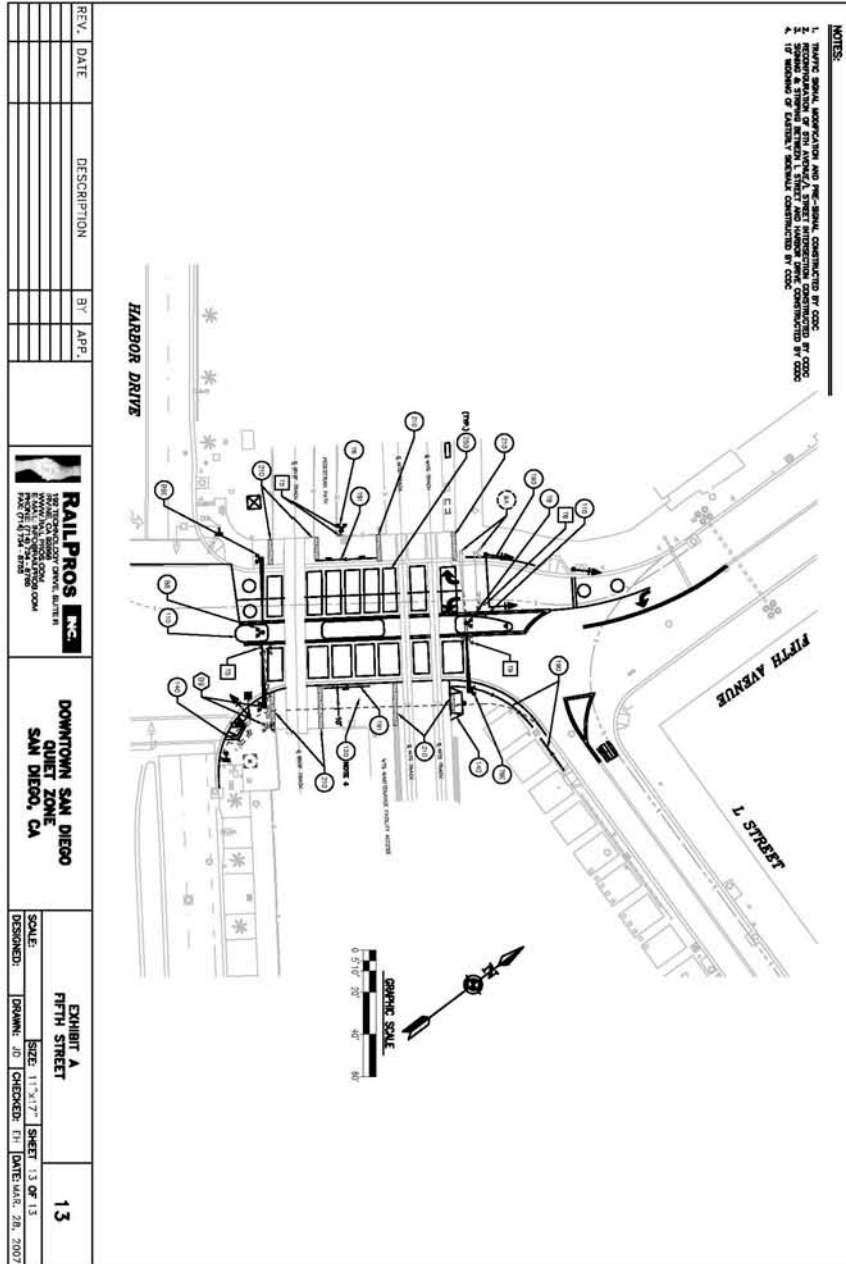

Exhibit B

Please see attachment – Kettner Street Signal Estimate

OTHER

CONTRACT CIVIL WORK	1.0 EA N	25,000	
CONTRACT ENGR.	1.0 EA N	15,000	
FILL DIRT	10.0 CY N	250	
SURFACE ROCK	10.0 CY N	250	
		<hr/>	
TOTAL OTHER ITEMS COST		40,500	40,500
			<hr/>
PROJECT SUBTOTAL			309,768
CONTINGENCIES			61,953
BILL PREPARATION FEE			3,718
			<hr/>
GROSS PROJECT COST			375,439
LESS COST PAID BY BNSF			0
			<hr/>
TOTAL BILLABLE COST			375,439

Exhibit B

Please see attachment – Market Street Signal Estimate

BNSF RAILWAY COMPANY
 FHPM ESTIMATE FOR
 CITY OF SAN DIEGO

LOCATION SAN DIEGO TO 22ND ST DETAILS OF ESTIMATE PLAN ITEM : PSI026875K VERSION : 1

PURPOSE, JUSTIFICATION AND DESCRIPTION

REVISED TO NEW PRICING LIST 09/04/03 (THERE WAS NO APPROVED MATERIAL LIST AT THIS TIME.)

INSTALL CONSTANT WARNING AND 2 ENT AND 2 EXIT GATES FOR BNSF SIDE OF SAN DIEGO QUIET ZONE AT MARKET ST IN SAN DIEGO, CA. CALIFORNIA DIV., SAN BERNARDINO SUBDIV., L/S 7600, M.P. 267.93, DOT # 026875K.

MONTHLY POWER UTILITY COST CENTER : 61692

THE MATERIAL LIST BELOW REFLECTS TYPICAL REPRESENTATIVE PACKAGES USED FOR ESTIMATING PURPOSE ONLY. THEY CAN BE EXPECTED TO CHANGE AFTER THE ENGINEERING PROCESS. DETAILED AND ACCURATE MATERIAL LISTS WILL BE FURNISHED WHEN ENGINEERING IS COMPLETED.

CONTINUING CONTRACTS HAVE BEEN ESTABLISHED FOR PORTIONS OF SIGNAL WORK ON THE BNSF RAILROAD. THIS ESTIMATE IS GOOD FOR 90 DAYS. THEREAFTER THE ESTIMATE IS SUBJECT TO CHANGE IN COST FOR LABOR, MATERIAL, AND OVERHEAD.

***** SIGNAL WORK ONLY *****

THE CITY OF SAN DIEGO IS FUNDING THIS PROJECT 100%.
 CONTINGENCIES SET AT 20%.
 MAINTAIN PROPRIETARY CONFIDENTIALITY

DESCRIPTION	QUANTITY	U/M	COST	TOTAL \$

LABOR				

SIGNAL FIELD LABOR - CAP	960.0	MH	28,916	
SIGNAL SHOP LABOR - CAP	80.0	MH	2,104	
PAYROLL ASSOCIATED COSTS			21,363	
EQUIPMENT EXPENSES			9,662	
DA LABOR OVERHEADS			33,333	
INSURANCE EXPENSES			4,882	
TOTAL LABOR COST			100,260	100,260

MATERIAL				

12C14	1000.0	FT N	2,420	
4% INFLATION RATE	1.0	LS N	11,484	
BATTERY	1.0	LS N	8,147	
BUNGALOW 8X10	1.0	EA N	11,381	
BUNGALOW MATERIAL	1.0	LS N	10,896	
CABLE	1.0	LS N	15,490	
CABLE, LOOP HR	1.0	LS N	5,025	
CHARGERS	1.0	LS N	1,215	
CONDUIT, PVC 4", SCH 80	200.0	FT N	780	
EGMS RACK	1.0	EA N	23,446	
EGMS, JCT BOX	2.0	EA N	744	
EGMS, MODULES	1.0	LS N	19,600	
FAILUP KIT	2.0	EA N	2,954	
FIELD MATERIAL	1.0	LS N	16,810	
FOUNDATION	4.0	EA N	1,936	
GATE ARM W/ LED LIGHTS	4.0	EA N	1,792	
GATE KEEPER	4.0	EA N	7,100	
GATE TIP SENSOR	4.0	EA N	256	
HXP3R	1.0	EA N	18,163	
ILOD	4.0	EA N	1,884	
INTERFACE BOX, LOOP DETECTION	1.0	EA N	258	
INTERFACE BOX, TRAFFIC PREEMPT	1.0	EA N	258	
LED LIGHT, 12" RETRO-FIT	16.0	EA N	3,584	
MODEL S-60, EXIT GATE MECH	2.0	EA N	14,486	
MODEL S-60, GATE MECH	2.0	EA N	14,486	
RECORDER	1.0	EA N	3,625	
RELAY W/BASE	25.0	EA N	12,500	
SHUNT, NBS	2.0	EA N	1,094	
SIDELIGHT COMPLETE	1.0	EA N	1,225	
TELLULAR MONITOR	1.0	EA N	2,500	
TIMER	1.0	EA N	2,203	

USE TAX		18,735	
OFFLINE TRANSPORTATION		2,728	
		<hr/>	
TOTAL MATERIAL COST		239,205	239,205

OTHER			

CONTRACT CIVIL WORK	1.0 LS N	25,000	
CONTRACT ENGINEERING	1.0 LS N	20,000	
FILL DIRT	10.0 CY N	250	
SURFACE ROCK	10.0 CY N	250	
		<hr/>	
TOTAL OTHER ITEMS COST		45,500	45,500
PROJECT SUBTOTAL			384,965
CONTINGENCIES			76,993
BILL PREPARATION FEE			4,620
			<hr/>
GROSS PROJECT COST			466,578
LESS COST PAID BY BNSF			0
			<hr/>
TOTAL BILLABLE COST			466,578

Exhibit B

Please see attachment –Front Street Signal Estimate

BNSF RAILWAY COMPANY
 FHPM ESTIMATE FOR
 CITY OF SAN DIEGO

LOCATION SAN DIEGO TO 22ND ST

DETAILS OF ESTIMATE

PLAN ITEM : PSI026935S

VERSION : 1

PURPOSE, JUSTIFICATION AND DESCRIPTION

INSTALL CONSTANT WARNING FOR BNSF SIDE OF SAN DIEGO QUIET ZONE AT FRONT ST IN SAN DIEGO, CA. CALIFORNIA DIV., SAN BERNARDINO SUBDIV., L/S 7600, M.P. 268.20, DOT # 026935S.

MONTHLY POWER UTILITY COST CENTER : 61692

THE MATERIAL LIST BELOW REFLECTS TYPICAL REPRESENTIVE PACKAGES USED FOR ESTIMATING PURPOSE ONLY. THEY CAN BE EXPECTED TO CHANGE AFTER THE ENGINEERING PROCESS. DETAILED AND ACCURATE MATERIAL LISTS WILL BE FURNISHED WHEN ENGINEERING IS COMPLETED. CONTINUING CONTRACTS HAVE BEEN ESTABLISHED FOR PORTIONS OF SIGNAL WORK ON THE BNSF RAILROAD. THIS ESTIMATE IS GOOD FOR 90 DAYS. THEREAFTER THE ESTIMATE IS SUBJECT TO CHANGE IN COST FOR LABOR, MATERIAL, AND OVERHEAD.

***** SIGNAL WORK ONLY *****

THE CITY OF SAN DIEGO IS FUNDING THIS PROJECT 100%.
 CONTINGENCIES SET AT 20%.
 MAINTAIN PROPRIETARY CONFIDENTIALITY.

REVISED TO NEW PRICING LIST 09/04/03

DESCRIPTION	QUANTITY U/M	COST	TOTAL \$

LABOR			

SIGNAL FIELD LABOR - CAP	384.0 MH	11,567	
SIGNAL SHOP LABOR - CAP	64.0 MH	1,684	
PAYROLL ASSOCIATED COSTS		9,125	
EQUIPMENT EXPENSES		4,127	
DA LABOR OVERHEADS		14,238	
INSURANCE EXPENSES		2,085	
TOTAL LABOR COST		42,826	42,826

MATERIAL			

12C14	1000.0 FT N	2,420	
4% INFLATION RATE	1.0 LS N	4,296	
BATTERY	1.0 LS N	3,483	
BUNGALOW 6X6	1.0 EA N	8,587	
BUNGALOW MATERIAL	1.0 LS N	3,107	
CABLE	1.0 LS N	1,140	
CHARGERS	1.0 LS N	684	
CONDUIT, PVC 4", SCH 80	60.0 FT N	234	
EVENT RECORDER	1.0 EA N	4,000	
FIELD MATERIAL	1.0 LS N	10,182	
FLASHER SIGNAL COMPLETE	2.0 EA N	10,450	
FOUNDATION	2.0 EA N	968	
HXP3R	1.0 EA N	18,163	
JCT BOX	1.0 EA N	260	
RELAY W/BASE	12.0 EA N	6,000	
SHUNT, NBS	2.0 EA N	1,060	
TELLULAR MONITOR	1.0 EA N	2,500	
TIMER	1.0 EA N	2,203	
USE TAX		6,856	
OFFLINE TRANSPORTATION		996	
TOTAL MATERIAL COST		87,589	87,589

OTHER			

CONTRACT ENGR.	1.0 EA N	15,000	
FILL DIRT	10.0 CY N	250	
SURFACE ROCK	10.0 CY N	250	
TOTAL OTHER ITEMS COST		15,500	15,500

PROJECT SUBTOTAL	145,915
CONTINGENCIES	29,183
BILL PREPARATION FEE	1,751
	<hr/>
GROSS PROJECT COST	176,849
LESS COST PAID BY BNSF	0
	<hr/>
TOTAL BILLABLE COST	176,849

Exhibit B

Please see attachment – First Street Signal Estimate

OTHER

CONTRACT CIVIL WORK	1.0 EA N	10,000	
CONTRACT ENGR.	1.0 EA N	15,000	
FILL DIRT	10.0 CY N	250	
SURFACE ROCK	10.0 CY N	250	
		<hr/>	
TOTAL OTHER ITEMS COST		25,500	25,500
			<hr/>
PROJECT SUBTOTAL			241,166
CONTINGENCIES			48,233
BILL PREPARATION FEE			2,894
			<hr/>
GROSS PROJECT COST			292,293
LESS COST PAID BY BNSF			0
			<hr/>
TOTAL BILLABLE COST			292,293

Exhibit B

Please see attachment – Fifth Street Signal Estimate

BNSF RAILWAY COMPANY
FHPM ESTIMATE FOR
CITY OF SAN DIEGO

LOCATION SAN DIEGO TO 22ND ST	DETAILS OF ESTIMATE	PLAN ITEM : PSI026878F	VERSION : 1
-------------------------------	---------------------	------------------------	-------------

PURPOSE, JUSTIFICATION AND DESCRIPTION

REVISED TO NEW PRICING LIST 09/04/03 (THERE WAS NO APPROVED MATERIAL LIST AT THIS TIME.)

INSTALL CONSTANT WARNING AND 2 ENT. AND 2 EXIT GATE FOR BNSF SIDE OF SAN DIEGO QUIET ZONE AT 5TH AVE IN SAN DIEGO, CA. CALIFORNIA DIV., SAN BERNARDINO SUBDIV., L/S 7600, M.P. 268.50, DOT # 026878F.

MONTHLY POWER UTILITY COST CENTER : 61692

THE MATERIAL LIST BELOW REFLECTS TYPICAL REPRESENTIVE PACKAGES USED FOR ESTIMATING PURPOSE ONLY. THEY CAN BE EXPECTED TO CHANGE AFTER THE ENGINEERING PROCESS. DETAILED AND ACCURATE MATERIAL LISTS WILL BE FURNISHED WHEN ENGINEERING IS COMPLETED.

CONTINUING CONTRACTS HAVE BEEN ESTABLISHED FOR PORTIONS OF SIGNAL WORK ON THE BNSF RAILROAD. THIS ESTIMATE IS GOOD FOR 90 DAYS. THEREAFTER THE ESTIMATE IS SUBJECT TO CHANGE IN COST FOR LABOR, MATERIAL, AND OVERHEAD.

***** SIGNAL WORK ONLY *****

THE CITY OF SAN DIEGO IS FUNDING THIS PROJECT 100%.
CONTINGENCIES SET AT 20%.

MAINTAIN PROPRIETARY CONFIDENTIALITY

DESCRIPTION	QUANTITY U/M	COST	TOTAL \$

LABOR			

SIGNAL FIELD LABOR - CAP	864.0 MH	26,024	
SIGNAL SHOP LABOR - CAP	80.0 MH	2,104	
PAYROLL ASSOCIATED COSTS		19,371	
EQUIPMENT EXPENSES		8,761	
DA LABOR OVERHEADS		30,225	
INSURANCE EXPENSES		4,427	
TOTAL LABOR COST		90,912	90,912

MATERIAL			

12C14	1000.0 FT N	2,560	
4% INFLATION RATE	1.0 LS N	6,696	
BATTERY	1.0 LS N	10,147	
BUNGALOW 8X10	1.0 EA N	11,381	
BUNGALOW MATERIAL	1.0 LS N	14,688	
CABLE	1.0 LS N	15,790	
CABLE, LOOP HR	1.0 LS N	5,025	
CHARGERS	1.0 LS N	1,215	
CONDUIT, PVC 4", SCH 80	200.0 FT N	780	
EGMS RACK	1.0 EA N	23,445	
EGMS, JCT BOX	2.0 EA N	744	
EGMS, MODULES	1.0 LS N	19,000	
EVENT RECORDER	1.0 EA N	4,000	
FAIL UP KIT	2.0 EA N	3,354	
FIELD MATERIAL	1.0 LS N	18,810	
FLASHER	1.0 EA N	3,267	
FOUNDATION, STEEL	3.0 EA N	1,620	
GATE ARM W/ LED LIGHTS	2.0 EA N	896	
GATE KEEPER	4.0 EA N	7,100	
HXP3R	1.0 EA N	18,163	
HXP3R2	1.0 EA N	18,890	
INTERFACE BOX, LOOP DETECTION	1.0 EA N	258	
INTERFACE BOX, TRAFFIC PREEMPT	1.0 EA N	258	
LED LIGHT, 12" RETRO-FIT	14.0 EA N	3,136	
MODEL S-60, EXIT GATE MECH	2.0 EA N	14,486	
MODEL S-60, GATE MECH	2.0 EA N	14,486	
RELAY W/BASE	30.0 EA N	15,000	
SHUNT, NBS	2.0 EA N	1,696	
SIDELIGHT COMPLETE	1.0 EA N	1,550	
TELLULAR MONITOR	1.0 EA N	2,500	
TIMER	1.0 EA N	2,203	

USE TAX		20,921	
OFFLINE TRANSPORTATION		3,051	
		<hr/>	
TOTAL MATERIAL COST		267,116	267,116

OTHER			

CONTRACT CIVIL WORK	1.0 LS N	50,000	
CONTRACT ENGINEERING	1.0 LS N	20,000	
FILL DIRT	10.0 CY N	250	
SURFACE ROCK	10.0 CY N	250	
		<hr/>	
TOTAL OTHER ITEMS COST		70,500	70,500
PROJECT SUBTOTAL			428,528
CONTINGENCIES			85,705
BILL PREPARATION FEE			5,143
			<hr/>
GROSS PROJECT COST			519,376
LESS COST PAID BY BNSF			0
			<hr/>
TOTAL BILLABLE COST			519,376

EXHIBIT "C" CONTRACTOR REQUIREMENTS

1.01 General

- **1.01.01** The Contractor must cooperate with **BNSF RAILWAY COMPANY**, hereinafter referred to as "Railway" where work is over or under on or adjacent to Railway property and/or right-of-way, hereafter referred to as "Railway Property", during the construction of San Diego Quiet Zone Project.
- **1.01.02** The Contractor must execute and deliver to the Railway duplicate copies of the Exhibit "C-1" Agreement, in the form attached hereto, obligating the Contractor to provide and maintain in full force and effect the insurance called for under Section 3 of said Exhibit "C-1". Questions regarding procurement of the Railroad Protective Liability Insurance should be directed to Rosa Martinez at Marsh, USA, 214-303-8519.
- **1.01.03** The Contractor must plan, schedule and conduct all work activities so as not to interfere with the movement of any trains on Railway Property.
- **1.01.04** The Contractor's right to enter Railway's Property is subject to the absolute right of Railway to cause the Contractor's work on Railway's Property to cease if, in the opinion of Railway, Contractor's activities create a hazard to Railway's Property, employees, and/or operations. Railway will have the right to stop construction work on the Project if any of the following events take place: (i) Contractor (or any of its subcontractors) performs the Project work in a manner contrary to the plans and specifications approved by Railway; (ii) Contractor (or any of its subcontractors), in Railway's opinion, prosecutes the Project work in a manner which is hazardous to Railway property, facilities or the safe and expeditious movement of railroad traffic; (iii) the insurance described in the attached Exhibit C-1 is canceled during the course of the Project; or (iv) Contractor fails to pay Railway for the Temporary Construction License or the Easement. The work stoppage will continue until all necessary actions are taken by Contractor or its subcontractor to rectify the situation to the satisfaction of Railway's Division Engineer or until additional insurance has been delivered to and accepted by Railway. In the event of a breach of (i) this Agreement, (ii) the Temporary Construction License, or (iii) the Easement, Railway may immediately terminate the Temporary Construction License or the Easement. Any such work stoppage under this provision will not give rise to any liability on the part of Railway. Railway's right to stop the work is in addition to any other rights Railway may have including, but not limited to, actions or suits for damages or lost profits. In the event that Railway desires to stop construction work on the Project, Railway agrees to immediately notify the following individual in writing:

Scott A. Johnson, PE
Senior Project Manager-Construction
Centre City Development Corporation (CCDC)
401 B Street, Suite 400
San Diego, CA 92101
Phone: 619-533-7108
Fax: 619-236-9148

- **1.01.05** The Contractor is responsible for determining and complying with all Federal, State and Local Governmental laws and regulations, including, but not limited to environmental laws and regulations (including but not limited to the Resource Conservation and Recovery Act, as amended; the Clean Water Act, the Oil Pollution Act, the Hazardous Materials Transportation Act, CERCLA), and health and safety laws and regulations. The Contractor hereby indemnifies, defends and holds harmless Railway for, from and against all fines or penalties imposed or assessed by Federal, State and Local Governmental Agencies against the Railway which arise out of Contractor's work under this Agreement.

- **1.01.06** The Contractor must notify the (City of San Diego) at (619) 533-3160 and Railway's Manager Public Projects, telephone number (909)386-4472 at least thirty (30) calendar days before commencing any work on Railway Property. Contractor's notification to Railway, must refer to Railroad's file "San Diego Quiet Zone."
- **1.01.07** For any bridge demolition and/or falsework above any tracks or any excavations located with any part of the excavations located within, whichever is greater, twenty-five (25) feet of the nearest track or intersecting a slope from the plane of the top of rail on a 2 horizontal to 1 vertical slope beginning at eleven (11) feet from centerline of the nearest track, both measured perpendicular to center line of track, the Contractor must furnish the Railway five sets of working drawings showing details of construction affecting Railway Property and tracks. The working drawing must include the proposed method of installation and removal of falsework, shoring or cribbing, not included in the contract plans and two sets of structural calculations of any falsework, shoring or cribbing. For all excavation and shoring submittal plans, the current "BNSF-UPRR Guidelines for Temporary Shoring" must be used for determining the design loading conditions to be used in shoring design, and all calculations and submittals must be in accordance with the current "BNSF-UPRR Guidelines for Temporary Shoring". All submittal drawings and calculations must be stamped by a registered professional engineer licensed to practice in the state the project is located. All calculations must take into consideration railway surcharge loading and must be designed to meet American Railway Engineering and Maintenance-of-Way Association (previously known as American Railway Engineering Association) Coopers E-80 live loading standard. All drawings and calculations must be stamped by a registered professional engineer licensed to practice in the state the project is located. The Contractor must not begin work until notified by the Railway that plans have been approved. The Contractor will be required to use lifting devices such as, cranes and/or winches to place or to remove any falsework over Railway's tracks. In no case will the Contractor be relieved of responsibility for results obtained by the implementation of said approved plans.
- **1.01.08** Subject to the movement of Railway's trains, Railway will cooperate with the Contractor such that the work may be handled and performed in an efficient manner. The Contractor will have no claim whatsoever for any type of damages or for extra or additional compensation in the event his work is delayed by the Railway.

1.02 Contractor Safety Orientation

- **1.02.01** No employee of the Contractor, its subcontractors, agents or invitees may enter Railway Property without first having completed Railway's Engineering Contractor Safety Orientation, found on the web site www.contractororientation.com. The Contractor must ensure that each of its employees, subcontractors, agents or invitees completes Railway's Engineering Contractor Safety Orientation through internet sessions before any work is performed on the Project. Additionally, the Contractor must ensure that each and every one of its employees, subcontractors, agents or invitees possesses a card certifying completion of the Railway Contractor Safety Orientation before entering Railway Property. The Contractor is responsible for the cost of the Railway Contractor Safety Orientation. The Contractor must renew the Railway Contractor Safety Orientation annually. Further clarification can be found on the web site or from the Railway's Representative.

1.03 Railway Requirements

- **1.03.01** The Contractor must take protective measures as are necessary to keep railway facilities, including track ballast, free of sand, debris, and other foreign objects and materials resulting from his operations. Any damage to railway facilities resulting from Contractor's operations will be repaired or replaced by Railway and the cost of such repairs or replacement must be paid for by the Agency.
- **1.03.02** The Contractor must notify the Railway's General Manager Mark Kirschinger at (909) 386-4150 and provide blasting plans to the Railway for review seven (7) calendar days prior to conducting any blasting operations adjacent to or on Railway's Property.
- **1.03.03** The Contractor must abide by the following temporary clearances during construction:

- 15' Horizontally from centerline of nearest track
 - 21'-6" Vertically above top of rail
 - 27'-0" Vertically above top of rail for electric wires carrying less than 750 volts
 - 28'-0" Vertically above top of rail for electric wires carrying 750 volts to 15,000 volts
 - 30'-0" Vertically above top of rail for electric wires carrying 15,000 volts to 20,000 volts
 - 34'-0" Vertically above top of rail for electric wires carrying more than 20,000 volts

- **1.03.04** Upon completion of construction, the following clearances shall be maintained:
 - 25' Horizontally from centerline of nearest track
 - 23'-3 1/2" Vertically above top of rail

- **1.03.05** Any infringement within State statutory clearances due to the Contractor's operations must be submitted to the Railway and to the City of San Diego and must not be undertaken until approved in writing by the Railway, and until the City of San Diego has obtained any necessary authorization from the State Regulatory Authority for the infringement. No extra compensation will be allowed in the event the Contractor's work is delayed pending Railway approval, and/or the State Regulatory Authority's approval.

- **1.03.06** In the case of impaired vertical clearance above top of rail, Railway will have the option of installing tell-tales or other protective devices Railway deems necessary for protection of Railway operations. The cost of tell-tales or protective devices will be borne by the Agency.

- **1.03.07** The details of construction affecting the Railway's Property and tracks not included in the contract plans must be submitted to the Railway by City of San Diego for approval before work is undertaken and this work must not be undertaken until approved by the Railway.

- **1.03.08** At other than public road crossings, the Contractor must not move any equipment or materials across Railway's tracks until permission has been obtained from the Railway. The Contractor must obtain a "Temporary Construction Crossing Agreement" from the Railway prior to moving his equipment or materials across the Railways tracks. The temporary crossing must be gated and locked at all times when not required for use by the Contractor. The temporary crossing for use of the Contractor will be constructed and, at the completion of the project, removed at the expense of the Contractor.

- **1.03.09** Discharge, release or spill on the Railway Property of any hazardous substances, oil, petroleum, constituents, pollutants, contaminants, or any hazardous waste is prohibited and Contractor must immediately notify the Railway's Resource Operations Center at 1(800) 832-5452, of any discharge, release or spills in excess of a reportable quantity. Contractor must not allow Railway Property to become a treatment, storage or transfer facility as those terms are defined in the Resource Conservation and Recovery Act or any state analogue.

- **1.03.10** The Contractor upon completion of the work covered by this contract, must promptly remove from the Railway's Property all of Contractor's tools, equipment, implements and other materials, whether brought upon said property by said Contractor or any Subcontractor, employee or agent of Contractor or of any Subcontractor, and must cause Railway's Property to be left in a condition acceptable to the Railway's representative.

1.04 Contractor Roadway Worker on Track Safety Program and Safety Action Plan

- 1.04.01 Each Contractor that will perform work within 25 feet of the centerline of a track must develop and implement a Roadway Worker Protection/On Track Safety Program and work with Railway Project Representative to develop an on track safety strategy as described in the guidelines listed in the on track safety portion of the Safety Orientation. This Program must provide Roadway Worker protection/on track training for all employees of the Contractor, its subcontractors, agents or invitees. This training is reinforced at the job site through job safety briefings. Additionally, each Contractor must develop and implement the Safety Action Plan,

as provided for on the web site www.contractororientation.com, which will be made available to Railway prior to commencement of any work on Railway Property. During the performance of work, the Contractor must audit its work activities. The Contractor must designate an on-site Project Supervisor who will serve as the contact person for the Railway and who will maintain a copy of the Safety Action Plan, safety audits, and Material Safety Datasheets (MSDS), at the job site.

- Contractor shall have a background investigation performed on all of its employees, subcontractors and agents who will be performing any services on railroad property under this Agreement.

The background screening shall at a minimum meet the criteria defined by the e-RAILSAFE program outlined at <http://www.e-railsafe.com> in addition to any other applicable regulatory requirements. The e-RAILSAFE program uses rail industry background screening standards.

Contractor shall obtain consent from all employees screened in compliance with the e-RAILSAFE program criteria to release completed background information to BNSF. Contractor shall be subject to periodic audit to ensure compliance.

Contractor shall not permit any of its employees, subcontractors or agents to perform services on property hereunder who are not approved under e-RAILSAFE program standards. Railroad shall have the right to deny entry onto its premises to any of Contractor's employees, subcontractors or agents who do not display the authorized identification badge issued by a background screening service meeting the standards set forth for the e-RAILSAFE program or who pose a threat, in Railroad's reasonable opinion, to the safety or security of Railroad's operations.

Contractors shall ensure its employees, subcontractors and agents are United States citizens or legally working in this country under a work VISA.

1.05 Railway Flagger Services:

- **1.05.01** The Contractor must give Railway's Roadmaster (telephone 909 386-4061) a minimum of thirty (30) calendar days advance notice when flagging services will be required so that the Roadmaster can make appropriate arrangements (i.e., bulletin the flagger's position). If flagging services are scheduled in advance by the Contractor and it is subsequently determined by the parties hereto that such services are no longer necessary, the Contractor must give the Roadmaster five (5) working days advance notice so that appropriate arrangements can be made to abolish the position pursuant to union requirements.
- **1.05.02** Unless determined otherwise by Railway's Project Representative, Railway flagger will be required and furnished when Contractor's work activities are located over, under and/or within twenty-five (25) feet measured horizontally from centerline of the nearest track and when cranes or similar equipment positioned beyond 25-feet from the track centerline could foul the track in the event of tip over or other catastrophic occurrence, but not limited thereto for the following conditions:
 - **1.05.02a** When, upon inspection by Railway's Representative, other conditions warrant.
 - **1.05.02b** When any excavation is performed below the bottom of tie elevation, if, in the opinion of Railway's representative, track or other Railway facilities may be subject to movement or settlement.
 - **1.05.02c** When work in any way interferes with the safe operation of trains at timetable speeds.
 - **1.05.02d** When any hazard is presented to Railway track, communications, signal, electrical, or other facilities either due to persons, material, equipment or blasting in the vicinity.
 - **1.05.02e** Special permission must be obtained from the Railway before moving heavy or cumbersome objects or equipment which might result in making the track impassable.
- **1.05.03** Flagging services will be performed by qualified Railway flaggers.

- **1.05.03a** Flagging crew generally consists of one employee. However, additional personnel may be required to protect Railway Property and operations, if deemed necessary by the Railways Representative.
- **1.05.03b** Each time a flagger is called, the minimum period for billing will be the eight (8) hour basic day.
- **1.05.03c** The cost of flagger services provided by the Railway will be borne by the (Agency). The estimated cost for one (1) flagger is approximately between \$800.00-\$1,600.00 for an eight (8) hour basic day with time and one-half or double time for overtime, rest days and holidays. The estimated cost for each flagger includes vacation allowance, paid holidays, Railway and unemployment insurance, public liability and property damage insurance, health and welfare benefits, vehicle, transportation, meals, lodging, radio, equipment, supervision and other costs incidental to performing flagging services. Negotiations for Railway labor or collective bargaining agreements and rate changes authorized by appropriate Federal authorities may increase actual or estimated flagging rates. **THE FLAGGING RATE IN EFFECT AT THE TIME OF PERFORMANCE BY THE CONTRACTOR HEREUNDER WILL BE USED TO CALCULATE THE ACTUAL COSTS OF FLAGGING PURSUANT TO THIS PARAGRAPH.**
- **1.05.03d** The average train traffic on this route is 4 freight trains per 24-hour period at a timetable speed 10 MPH and 0 passenger trains at a timetable speed of 20 MPH.

1.06 Contractor General Safety Requirements

- **1.06.01** Work in the proximity of railway track(s) is potentially hazardous where movement of trains and equipment can occur at any time and in any direction. All work performed by contractors within 25 feet of any track must be in compliance with FRA Roadway Worker Protection Regulations.
- **1.06.02** Before beginning any task on Railway Property, a thorough job safety briefing must be conducted with all personnel involved with the task and repeated when the personnel or task changes. If the task is within 25 feet of any track, the job briefing must include the Railway's flagger, as applicable, and include the procedures the Contractor will use to protect its employees, subcontractors, agents or invitees from moving any equipment adjacent to or across any Railway track(s).
- **1.06.03** Workers must not work within 25 feet of the centerline of any track without an on track safety strategy approved by the Railway's Project Representative. When authority is provided, every contractor employee must know: (1) who the Railway flagger is, and how to contact the flagger, (2) limits of the authority, (3) the method of communication to stop and resume work, and (4) location of the designated places of safety. Persons or equipment entering flag/work limits that were not previously job briefed, must notify the flagger immediately, and be given a job briefing when working within 25 feet of the center line of track.
- **1.06.04** When Contractor employees are required to work on the Railway Property after normal working hours or on weekends, the Railroad's representative in charge of the project must be notified. A minimum of two employees must be present at all times.
- **1.06.05** Any employees, agents or invitees of Contractor or its subcontractors under suspicion of being under the influence of drugs or alcohol, or in the possession of same, will be removed from the Railway's Property and subsequently released to the custody of a representative of Contractor management. Future access to the Railway's Property by that employee will be denied.
- **1.06.06** Any damage to Railway Property, or any hazard noticed on passing trains must be reported immediately to the Railway's representative in charge of the project. Any vehicle or machine which may come in contact with track, signal equipment, or structure (bridge) and could result in a train derailment must be reported immediately to the Railway representative in charge of the project and to the Railway's Resource Operations Center at 1(800) 832-5452. Local emergency numbers are to be obtained from the Railway representative in charge of the project prior to the start of any work and must be posted at the job site.

- **1.06.07** For safety reasons, all persons are prohibited from having pocket knives, firearms or other deadly weapons in their possession while working on Railway's Property.
- **1.06.08** All personnel protective equipment (PPE) used on Railway Property must meet applicable OSHA and ANSI specifications. Current Railway personnel protective equipment requirements are listed on the web site, www.contractororientation.com, however, a partial list of the requirements include: a) safety glasses with permanently affixed side shields (no yellow lenses); b) hard hats c) safety shoe with: hardened toes, above-the-ankle lace-up and a defined heel; and d) high visibility retro-reflective work wear. The Railroad's representative in charge of the project is to be contacted regarding local specifications for meeting requirements relating to hi-visibility work wear. Hearing protection, fall protection, gloves, and respirators must be worn as required by State and Federal regulations. **(NOTE – Should there be a discrepancy between the information contained on the web site and the information in this paragraph, the web site will govern.)**
- **1.06.09 THE CONTRACTOR MUST NOT PILE OR STORE ANY MATERIALS, MACHINERY OR EQUIPMENT CLOSER THAN 25'-0" TO THE CENTER LINE OF THE NEAREST RAILWAY TRACK. MATERIALS, MACHINERY OR EQUIPMENT MUST NOT BE STORED OR LEFT WITHIN 250 FEET OF ANY HIGHWAY/RAIL AT-GRADE CROSSINGS OR TEMPORARY CONSTRUCTION CROSSING, WHERE STORAGE OF THE SAME WILL OBSTRUCT THE VIEW OF A TRAIN APPROACHING THE CROSSING. PRIOR TO BEGINNING WORK, THE CONTRACTOR MUST ESTABLISH A STORAGE AREA WITH CONCURRENCE OF THE RAILROAD'S REPRESENTATIVE.**
- **1.06.10** Machines or vehicles must not be left unattended with the engine running. Parked machines or equipment must be in gear with brakes set and if equipped with blade, pan or bucket, they must be lowered to the ground. All machinery and equipment left unattended on Railway's Property must be left inoperable and secured against movement. (See internet Engineering Contractor Safety Orientation program for more detailed specifications)
- **1.06.11** Workers must not create and leave any conditions at the work site that would interfere with water drainage. Any work performed over water must meet all Federal, State and Local regulations.
- **1.06.12** All power line wires must be considered dangerous and of high voltage unless informed to the contrary by proper authority. For all power lines the minimum clearance between the lines and any part of the equipment or load must be; 200 KV or below - 15 feet; 200 to 350 KV - 20 feet; 350 to 500 KV - 25 feet; 500 to 750 KV - 35 feet; and 750 to 1000 KV - 45 feet. If capacity of the line is not known, a minimum clearance of 45 feet must be maintained. A person must be designated to observe clearance of the equipment and give a timely warning for all operations where it is difficult for an operator to maintain the desired clearance by visual means.

1.07 Excavation

- **1.07.01** Before excavating, the Contractor must determine whether any underground pipe lines, electric wires, or cables, including fiber optic cable systems are present and located within the Project work area. The Contractor must determine whether excavation on Railway's Property could cause damage to buried cables resulting in delay to Railway traffic and disruption of service to users. Delays and disruptions to service may cause business interruptions involving loss of revenue and profits. Before commencing excavation, the Contractor must contact **BNSF's Field Engineering Representative (Greg Rousseau, 909-386-4079)**. All underground and overhead wires will be considered HIGH VOLTAGE and dangerous until verified with the company having ownership of the line. **It is the Contractor's responsibility to notify any other companies that have underground utilities in the area and arrange for the location of all underground utilities before excavating.**
- **1.07.02** The Contractor must cease all work and notify the Railway immediately before continuing excavation in the area if obstructions are encountered which do not appear on drawings. If the obstruction is a utility and

the owner of the utility can be identified, then the Contractor must also notify the owner immediately. If there is any doubt about the location of underground cables or lines of any kind, no work must be performed until the exact location has been determined. There will be no exceptions to these instructions.

- **1.07.03** All excavations must be conducted in compliance with applicable OSHA regulations and, regardless of depth, must be shored where there is any danger to tracks, structures or personnel.
- **1.07.04** Any excavations, holes or trenches on the Railway's Property must be covered, guarded and/or protected when not being worked on. When leaving work site areas at night and over weekends, the areas must be secured and left in a condition that will ensure that Railway employees and other personnel who may be working or passing through the area are protected from all hazards. All excavations must be back filled as soon as possible.

1.08 Hazardous Waste, Substances and Material Reporting

- **1.08.01** If Contractor discovers any hazardous waste, hazardous substance, petroleum or other deleterious material, including but not limited to any non-containerized commodity or material, on or adjacent to Railway's Property, in or near any surface water, swamp, wetlands or waterways, while performing any work under this Agreement, Contractor must immediately: (a) notify the Railway's Resource Operations Center at 1(800) 832-5452, of such discovery; (b) take safeguards necessary to protect its employees, subcontractors, agents and/or third parties; and (c) exercise due care with respect to the release, including the taking of any appropriate measure to minimize the impact of such release.

1.09 Personal Injury Reporting

- **1.09.01** The Railway is required to report certain injuries as a part of compliance with Federal Railroad Administration (FRA) reporting requirements. Any personal injury sustained by an employee of the Contractor, subcontractor or Contractor's invitees while on the Railway's Property must be reported immediately (by phone mail if unable to contact in person) to the Railway's representative in charge of the project. The Non-Employee Personal Injury Data Collection Form contained herein is to be completed and sent by Fax to the Railway at 1(817) 352-7595 and to the Railway's Project Representative no later than the close of shift on the date of the injury.

NON-EMPLOYEE PERSONAL INJURY DATA COLLECTION

INFORMATION REQUIRED TO BE COLLECTED PURSUANT TO FEDERAL REGULATION. IT SHOULD BE USED FOR COMPLIANCE WITH FEDERAL REGULATIONS ONLY AND IS NOT INTENDED TO PRESUME ACCEPTANCE OF RESPONSIBILITY OR LIABILITY.

- 1. Accident City/St _____ 2. Date: _____ Time:
County: _____ 3. Temperature: _____ 4. Weather
(if non-Railway location)
- 5. Social Security #
- 6. Name (last, first, mi)
- 7. Address: Street: _____ City: _____ St. _____ Zip:
- 8. Date of Birth: _____ and/or Age _____ Gender:
(if available)
- 9. (a) Injury: _____ (b) Body Part:
(i.e. (a) Laceration (b) Hand)
- 11. Description of Accident (To include location, action, result, etc.):

- 12. Treatment:
 - " First Aid Only
 - " Required Medical Treatment
 - " Other Medical Treatment

- 13. Dr. Name _____ 30. Date:
- 14. Dr. Address:
Street: _____ City: _____ St: _____ Zip:
- 15. Hospital Name:
- 16. Hospital Address:
Street: _____ City: _____ St: _____ Zip:
- 17. Diagnosis:

**FAX TO
RAILWAY AT (817) 352-7595
AND COPY TO
RAILWAY ROADMASTER FAX**

EXHIBIT "C-1"

**Agreement
Between
BNSF RAILWAY COMPANY
and the
CONTRACTOR**

BNSF RAILWAY COMPANY
Attention: Manager Public Projects

Railway File: San Diego QZ Project

Agency Project: _____

Gentlemen:

The undersigned (hereinafter called, the "Contractor"), has entered into a contract (the "Contract") dated _____, 2010, *****Drafter's Note: insert the date of the contract between the Agency and the Contractor here**] with the **City of San Diego** for the performance of certain work in connection with the following project: San Diego QZ Project. Performance of such work will necessarily require contractor to enter **BNSF RAILWAY COMPANY** ("Railway") right of way and property ("Railway Property"). The Contract provides that no work will be commenced within Railway Property until the Contractor employed in connection with said work for **City of San Diego** (i) executes and delivers to Railway an Agreement in the form hereof, and (ii) provides insurance of the coverage and limits specified in such Agreement and Section 3 herein. If this Agreement is executed by a party who is not the Owner, General Partner, President or Vice President of Contractor, Contractor must furnish evidence to Railway certifying that the signatory is empowered to execute this Agreement on behalf of Contractor.

Accordingly, in consideration of Railway granting permission to Contractor to enter upon Railway Property and as an inducement for such entry, Contractor, effective on the date of the Contract, has agreed and does hereby agree with Railway as follows:

Section 1. RELEASE OF LIABILITY AND INDEMNITY

Contractor hereby waives, releases, indemnifies, defends and holds harmless Railway for all judgments, awards, claims, demands, and expenses (including attorneys' fees), for injury or death to all persons, including Railway's and Contractor's officers and employees, and for loss and damage to property belonging to any person, arising in any manner from Contractor's or any of Contractor's subcontractors' acts or omissions or any work performed on or about Railway's property or right-of-way. **THE LIABILITY ASSUMED BY CONTRACTOR WILL NOT BE AFFECTED BY THE FACT, IF IT IS A FACT, THAT THE DESTRUCTION, DAMAGE, DEATH, OR INJURY WAS OCCASIONED BY OR CONTRIBUTED TO BY THE NEGLIGENCE OF RAILWAY, ITS AGENTS, SERVANTS, EMPLOYEES OR OTHERWISE, EXCEPT TO THE EXTENT THAT SUCH CLAIMS ARE PROXIMATELY CAUSED BY THE WILLFUL MISCONDUCT OR SOLE NEGLIGENCE OF RAILWAY.**

THE INDEMNIFICATION OBLIGATION ASSUMED BY CONTRACTOR INCLUDES ANY CLAIMS, SUITS OR JUDGMENTS BROUGHT AGAINST RAILWAY UNDER THE FEDERAL EMPLOYEE'S LIABILITY ACT, INCLUDING CLAIMS FOR STRICT LIABILITY UNDER THE SAFETY APPLIANCE ACT OR THE LOCOMOTIVE INSPECTION ACT, WHENEVER SO CLAIMED.

Contractor further agrees, at its expense, in the name and on behalf of Railway, that it will adjust and settle all claims made against Railway, and will, at Railway's discretion, appear and defend any suits or actions of law or

in equity brought against Railway on any claim or cause of action arising or growing out of or in any manner connected with any liability assumed by Contractor under this Agreement for which Railway is liable or is alleged to be liable. Railway will give notice to Contractor, in writing, of the receipt or dependency of such claims and thereupon Contractor must proceed to adjust and handle to a conclusion such claims, and in the event of a suit being brought against Railway, Railway may forward summons and complaint or other process in connection therewith to Contractor, and Contractor, at Railway's discretion, must defend, adjust, or settle such suits and protect, indemnify, and save harmless Railway from and against all damages, judgments, decrees, attorney's fees, costs, and expenses growing out of or resulting from or incident to any such claims or suits.

In addition to any other provision of this Agreement, in the event that all or any portion of this Article shall be deemed to be inapplicable for any reason, including without limitation as a result of a decision of an applicable court, legislative enactment or regulatory order, the parties agree that this Article shall be interpreted as requiring Contractor to indemnify Railroad to the fullest extent permitted by applicable law. **THROUGH THIS AGREEMENT THE PARTIES EXPRESSLY INTEND FOR CONTRACTOR TO INDEMNIFY RAILROAD FOR RAILROAD'S ACTS OF NEGLIGENCE.**

It is mutually understood and agreed that the assumption of liabilities and indemnification provided for in this Agreement survive any termination of this Agreement.

Section 2. TERM

This Agreement is effective from the date of the Contract until (i) the completion of the project set forth herein, and (ii) full and complete payment to Railway of any and all sums or other amounts owing and due hereunder.

Section 3. INSURANCE

Contractor must, at its sole cost and expense, procure and maintain during the life of this Agreement the following insurance coverage:

- A. Commercial General Liability insurance. This insurance shall contain broad form contractual liability with a combined single limit of a minimum of \$2,000,000 each occurrence and an aggregate limit of at least \$4,000,000 but in no event less than the amount otherwise carried by the contractor. Coverage must be purchased on a post 1998 ISO occurrence form or equivalent and include coverage for, but not limit to the following:
- ◆ Bodily Injury and Property Damage
 - ◆ Personal Injury and Advertising Injury
 - ◆ Fire legal liability
 - ◆ Products and completed operations

This policy must also contain the following endorsements, which must be indicated on the certificate of insurance:

- ◆ The definition of insured contract must be amended to remove any exclusion or other limitation for any work being done within 50 feet of railroad property.
- ◆ Waiver of subrogation in favor of and acceptable to Railroad.
- ◆ Additional insured endorsement in favor of and acceptable to Railroad.
- ◆ Separation of insureds.
- ◆ The policy shall be primary and non-contributing with respect to any insurance carried by Railroad.

It is agreed that any workers' compensation exclusion does not apply to **Railroad** payments related to the Federal Employers Liability Act or a **Railroad** Wage Continuation Program or similar programs and any

payments made are deemed not to be either payments made or obligations assumed under any Workers Compensation, disability benefits, or unemployment compensation law or similar law.

No other endorsements limiting coverage as respects obligations under this Agreement may be included on the policy with regard to the work being performed under this agreement.

B. Business Automobile Insurance. This insurance must contain a combined single limit of at least \$1,000,000 per occurrence, and include coverage for, but not limited to the following:

- ◆ Bodily injury and property damage
- ◆ Any and all vehicles owned, used or hired

The policy shall also contain the following endorsements or language, which shall be indicated on the certificate of insurance:

- ◆ Waiver of subrogation in favor of and acceptable to Railroad.
- ◆ Additional insured endorsement in favor of and acceptable to Railroad.
- ◆ Separation of insureds.
- ◆ The policy shall be primary and non-contributing with respect to any insurance carried by Railroad.

C. Workers Compensation and Employers Liability insurance including coverage for, but not limited to:

- ◆ Contractor's statutory liability under the worker's compensation laws of the state(s) in which the work is to be performed. If optional under State law, the insurance must cover all employees anyway.
- ◆ Employers' Liability (Part B) with limits of at least \$500,000 each accident, \$500,000 by disease policy limit, \$500,000 by disease each employee.

This policy shall also contain the following endorsements or language, which shall be indicated on the certificate of insurance:

- ◆ Waiver of subrogation in favor of and acceptable to Railroad.

D. Railroad Protective Liability insurance naming only the **Railroad** as the Insured with coverage of at least \$2,000,000 per occurrence and \$6,000,000 in the aggregate. The policy Must be issued on a standard ISO form CG 00 35 10 93 and include the following:

- ◆ Endorsed to include the Pollution Exclusion Amendment (ISO form CG 28 31 10 93)
- ◆ Endorsed to include the Limited Seepage and Pollution Endorsement.
- ◆ Endorsed to remove any exclusion for punitive damages.
- ◆ No other endorsements restricting coverage may be added.
- ◆ The original policy must be provided to the **Railroad** prior to performing any work or services under this Agreement

In lieu of providing a Railroad Protective Liability Policy, Licensee may participate in Licensor's Blanket Railroad Protective Liability Insurance Policy available to contractor.

Other Requirements:

All policies (applying to coverage listed above) must not contain an exclusion for punitive damages and certificates of insurance must reflect that no exclusion exists.

Contractor agrees to waive its right of recovery against **Railroad** for all claims and suits against **Railroad**. In addition, its insurers, through the terms of the policy or policy endorsement, waive their right of subrogation

against **Railroad** for all claims and suits. The certificate of insurance must reflect the waiver of subrogation endorsement. Contractor further waives its right of recovery, and its insurers also waive their right of subrogation against **Railroad** for loss of its owned or leased property or property under contractor's care, custody or control.

Contractor is not allowed to self-insure without the prior written consent of **Railroad**. If granted by **Railroad**, any deductible, self-insured retention or other financial responsibility for claims must be covered directly by contractor in lieu of insurance. Any and all **Railroad** liabilities that would otherwise, in accordance with the provisions of this **Agreement**, be covered by contractor's insurance will be covered as if contractor elected not to include a deductible, self-insured retention or other financial responsibility for claims.

Prior to commencing the Work, contractor must furnish to **Railroad** an acceptable certificate(s) of insurance including an original signature of the authorized representative evidencing the required coverage, endorsements, and amendments and referencing the contract audit/folder number if available. The policy(ies) must contain a provision that obligates the insurance company(ies) issuing such policy(ies) to notify **Railroad** in writing at least 30 days prior to any cancellation, non-renewal, substitution or material alteration. This cancellation provision must be indicated on the certificate of insurance. Upon request from **Railroad**, a certified duplicate original of any required policy must be furnished. Contractor should send the certificate(s) to the following address:

Ebix BPO
PO Box 12010-BN
Hemet, CA 92546-8010
Fax number: 951-652-2882
Email: bnsf@ebix.com

Any insurance policy must be written by a reputable insurance company acceptable to **Railroad** or with a current Best's Guide Rating of A- and Class VII or better, and authorized to do business in the state(s) in which the service is to be provide.

Contractor represents that this **Agreement** has been thoroughly reviewed by contractor's insurance agent(s)/broker(s), who have been instructed by contractor to procure the insurance coverage required by this **Agreement**. Allocated Loss Expense must be in addition to all policy limits for coverages referenced above. Not more frequently than once every five years, **Railroad** may reasonably modify the required insurance coverage to reflect then-current risk management practices in the railroad industry and underwriting practices in the insurance industry.

If any portion of the operation is to be subcontracted by contractor, contractor must require that the subcontractor provide and maintain the insurance coverages set forth herein, naming **Railroad** as an additional insured, and requiring that the subcontractor release, defend and indemnify **Railroad** to the same extent and under the same terms and conditions as contractor is required to release, defend and indemnify **Railroad** herein.

Failure to provide evidence as required by this section will entitle, but not require, **Railroad** to terminate this **Agreement** immediately. Acceptance of a certificate that does not comply with this section will not operate as a waiver of contractor's obligations hereunder.

The fact that insurance (including, without limitation, self-insurance) is obtained by contractor will not be deemed to release or diminish the liability of contractor including, without limitation, liability under the indemnity provisions of this **Agreement**. Damages recoverable by **Railroad** will not be limited by the amount of the required insurance coverage.

For purposes of this section, **Railroad** means "Burlington Northern Santa Fe Corporation", "BNSF RAILWAY COMPANY" and the subsidiaries, successors, assigns and affiliates of each.

Section 4. EXHIBIT "C" CONTRACTOR REQUIREMENTS

The Contractor must observe and comply with all provisions, obligations, requirements and limitations contained in the Contract, and the Contractor Requirements set forth on Exhibit "C" attached to the Contract and this Agreement, , including, but not be limited to, payment of all costs incurred for any damages to Railway roadbed, tracks, and/or appurtenances thereto, resulting from use, occupancy, or presence of its employees, representatives, or agents or subcontractors on or about the construction site.

Section 5. TRAIN DELAY

Contractor is responsible for and hereby indemnifies and holds harmless Railway (including its affiliated railway companies, and its tenants) for, from and against all damages arising from any unscheduled delay to a freight or passenger train which affects Railway's ability to fully utilize its equipment and to meet customer service and contract obligations. Contractor will be billed, as further provided below, for the economic losses arising from loss of use of equipment, contractual loss of incentive pay and bonuses and contractual penalties resulting from train delays, whether caused by Contractor, or subcontractors, or by the Railway performing work under this Agreement. Railway agrees that it will not perform any act to unnecessarily cause train delay.

For loss of use of equipment, Contractor will be billed the current freight train hour rate per train as determined from Railway's records. Any disruption to train traffic may cause delays to multiple trains at the same time for the same period.

Additionally, the parties acknowledge that passenger, U.S. mail trains and certain other grain, intermodal, coal and freight trains operate under incentive/penalty contracts between Railway and its customer(s). Under these arrangements, if Railway does not meet its contract service commitments, Railway may suffer loss of performance or incentive pay and/or be subject to penalty payments. Contractor is responsible for any train performance and incentive penalties or other contractual economic losses actually incurred by Railway which are attributable to a train delay caused by Contractor or its subcontractors.

The contractual relationship between Railway and its customers is proprietary and confidential. In the event of a train delay covered by this Agreement, Railway will share information relevant to any train delay to the extent consistent with Railway confidentiality obligations. Damages for train delay are currently \$382.20 per hour per incident. **THE RATE THEN IN EFFECT AT THE TIME OF PERFORMANCE BY THE CONTRACTOR HEREUNDER WILL BE USED TO CALCULATE THE ACTUAL COSTS OF TRAIN DELAY PURSUANT TO THIS AGREEMENT.**

Contractor and its subcontractors must give Railway's representative (Greg Rousseau – 909-386-4079) four (4) weeks advance notice of the times and dates for proposed work windows. Railway and Contractor will establish mutually agreeable work windows for the project. Railway has the right at any time to revise or change the work windows due to train operations or service obligations. Railway will not be responsible for any additional costs or expenses resulting from a change in work windows. Additional costs or expenses resulting from a change in work windows shall be accounted for in Contractor's expenses for the project.

Contractor and subcontractors must plan, schedule, coordinate and conduct all Contractor's work so as to not cause any delays to any trains.

Kindly acknowledge receipt of this letter by signing and returning to the Railway two original copies of this letter, which, upon execution by Railway, will constitute an Agreement between us.

Contractor

BNSF Railway Company

By: _____

By: _____

Printed Name: _____

Name: _____
Manager Public Projects

Title: _____

Accepted and effective this _____ day of 20__.

Contact Person: _____

Address: _____

City: _____

State: _____ Zip: _____

Fax: _____

Phone: _____

E-mail: _____